



Power to Ontario.
On Demand.

Market Manual 3: Metering
Part 3.6: Conceptual
Drawing Review

Issue 13.0

This section of the Market Metering Manual provides guidance to *metering service providers* and *metered market participants* on how to submit conceptual drawings for proposed *metering installations* and changes to existing *metering installations* to the IESO for review.

Disclaimer

The posting of documents on this Web site is done for the convenience of *market participants* and other interested visitors to the *IESO* Web site. Please be advised that, while the *IESO* attempts to have all posted documents conform to the original, changes can result from the original, including changes resulting from the programs used to format the documents for posting on the Web site as well as from the programs used by the viewer to download and read the documents. The *IESO* makes no representation or warranty, express or implied, that the documents on this Web site are exact reproductions of the original documents listed. In addition, the documents and information posted on this Web site are subject to change. The *IESO* may revise, withdraw or make final these materials at any time at its sole discretion without further notice. It is solely your responsibility to ensure that you are using up-to-date documents and information.

This *market manual* may contain a summary of a particular *market rule*. Where provided, the summary has been used because of the length of the *market rule* itself. The reader should be aware, however, that where a *market rule* is applicable, the obligation that needs to be met is as stated in the *market rules*. To the extent of any discrepancy or inconsistency between the provisions of a particular *market rule* and the summary, the provision of the *market rule* shall govern.

Document ID	MDP_PRO_0012
Document Name	Part 3.6: Conceptual Drawing Review
Issue	Issue 13.0
Reason for Issue	Released for Baseline 28.0
Effective Date	September 12, 2012

Document Change History

Issue	Reason for Issue	Date
1.0	Approved by the IESO Board.	April 7, 2000
2.0	Board approved version released for Baseline 3	June 2, 2000
3.0	Released for Baseline 6.2	May 17, 2000
4.0	Released for Baseline 7.0	January 16, 2002
5.0	Revisions to Examples of Conceptual Drawings	March 25, 2002
6.0	Revisions to incorporate Legal review	April 23, 2002
7.0	Issued for Baseline 9.1	June 4, 2003
8.0	Issued for Baseline 11.1	June 2, 2004
9.0	Released for Baseline 12.1	December 8, 2004
10.0	Released for Baseline 15.0	March 8, 2006
11.0	Released for Baseline 16.1	December 6, 2006
12.0	Updated for Baseline 21.1	June 3, 2009
13.0	Updated for Baseline 28.0	September 12, 2012

Related Documents

Document ID	Document Title
MDP_MAN_0003	Market Manual 3: Metering, Part 3.0: Metering Overview
MDP_PRO_0013	Market Manual 3: Metering, Part 3.2: Meter Point Registration and Maintenance
MDP_STD_0004	Wholesale Revenue Metering Standard - Hardware

Table of Contents

Table of Contents	i
List of Figures	ii
List of Tables	iii
Table of Changes	iv
Market Manuals	1
Market Procedures	1
1. Introduction	2
1.1 Purpose.....	2
1.2 Scope.....	2
1.3 Overview	2
1.4 Roles and Responsibilities	3
1.5 Required Format for Drawing Submissions	3
1.6 Required Information for SLD Submission.....	3
1.7 Disclaimer for IESO Review of Conceptual Drawings of Metering Installations	6
1.8 Contact Information.....	7
2. Procedural Work Flow	8
3. Procedural Steps	10
Appendix A: Forms	A-1
Appendix B: Illustrative Examples of Typical Concept Drawings	B-1
References	1

List of Figures

Figure 2-1: Procedural Work Flow for Conceptual Drawing Review	9
Figure B-1: SLD for a Transformer Station	B-1
Figure B-1: SLD for a Transformer Station (continued)	B-2
Figure B-2: SLD for an Embedded Load/Generator.....	B-3
Figure B-3: SLD for Generation	B-4

Archive

List of Tables

Table 1-1: SLD information	4
Table 2-1: Legend for Procedural Work Flow Diagrams	8
Table 3-1: Procedural Steps for Conceptual Drawing Review	11

Archive

Table of Changes

Reference	Description of Change
Section 1.0	In Table 1-1: SLD Information replaced PLC with CDMS.

Archive

Market Manuals

The *market manuals* consolidate external procedures and associated forms, standards, and policies that define certain elements relating to the operation of the *IESO-administered markets*. External procedures are guides for the use of *market participants* that provide a more detailed description of the requirements for various activities than is specified in the *market rules*. Standards and policies provide a supporting framework for the external procedures. Where there is a discrepancy between the requirements in a document within a *market manual* and the *market rules*, the *market rules* shall prevail.

Market Procedures

The “Metering Manual” is volume 3 of the *market manuals*, where this document is “*Part 3.6 Conceptual Drawing Review*”.

A list of the other component parts of the “Metering Manual” is provided “Part 3.0: Metering Overview”, in Section 2, “About this Manual”.

Structure of Market Procedures

Each External Procedure is composed of the following sections:

“**Introduction**”, which contains general information about the procedure, including an overview, a description of the purpose and scope of the procedure, and information about roles and responsibilities of the parties involved in the procedure.

“**Procedural Work Flow**”, which contains a graphical representation of the steps and flow of information within the procedure.

“**Procedural Steps**”, which contains a table that describes each step and provides other details related to each step.

“**Appendices**”, which may include such items as forms, standards, policies, and agreements.

Conventions

The *market manual* standard conventions are defined in the “Market Manual Overview” document.

– End of Section –

1. Introduction

1.1 Purpose

The purpose of the Conceptual Drawing Review (CDR) procedure is to outline the procedure to be followed by *market participants* when preparing and submitting single line diagrams (SLD) of proposed *metering installations* or of proposed changes to existing *metering installations* to the *IESO* for review. In addition, *metering service providers* may use certain information provided by this procedure when preparing the SLD in support of registration of a *metering installation* or of registering changes to a *metering installation*.

Please note that the *IESO* provides this review as a service to *market participants*. The *IESO* does not require a CDR for its own purposes and reviews the drawings solely upon request from the *metered market participant* or the *metering service provider*.

1.2 Scope

The procedure is intended to provide *market participants* with a summary of the steps and interfaces between *market participants*, the *IESO*, and other parties in performing a CDR. The procedural steps and work flows described in this document serve as a roadmap for *market participants* and the *IESO*, and should be used in conjunction with the *market rules*. The overview information in Section 1.3, below, is provided for context purposes and, therefore, only highlights the main actions that comprise the procedure.

The definition of a *metering installation* for the purpose of this document is identical to the one given in the *IESO* standard, “Wholesale Revenue Metering Standard-Hardware”.

The CDR procedure is available to *metered market participants* and *metering service providers* and covers proposed new *metering installations* and existing *metering installations* where changes to equipment, parameters or settings is contemplated.

Additional information that may be consulted when completing and submitting the CDR package can be found in the *IESO* standard, “Wholesale Revenue Metering Standard-Hardware”.

1.3 Overview

Metered market participants and *metering service providers* may prepare and submit SLDs detailing their proposed *metering installations* or changes to equipment, parameters or settings within their existing *metering installations* to the *IESO* for purposes of a CDR. This service is provided under the *market rules*, Chapter 6, Section 4.1.4 for new installations, and Chapter 6, Section 9.3.3 for existing installations.

For CDR: Drawing submissions must include the 16 of the 20 key items listed in Table 1-1, Section 1.6 of this manual (see Appendix B for illustrative examples of typical conceptual drawings). A “Conceptual Drawing Review Submission Form” (IMO-FORM-1043) must also accompany the submission.

For SLD: For Metering Installation Registration all 20 items must be completed.

1.4 Roles and Responsibilities

Responsibility for carrying out the CDR process is shared among:

- *Metering service providers* or *metered market participants*, which are responsible for:
 - Completing and submitting SLDs and the “Conceptual Drawing Review Submission Form” to the *IESO*.
- The *IESO*, which is responsible for:
 - Reviewing proposed SLDs; and
 - Notifying *metering service providers* or *metered market participants* of the results of the review.

1.5 Required Format for Drawing Submissions

SLDs must conform to the standard *IESO* format. For electronic submissions emailed to the *IESO*, the format is the graphics software package Visio 2000. Alternatively, hard copies are also acceptable. For illustrative examples of typical layouts, see Appendix B.

Note: The size limit for hard copies is 11” x 17”.

Please note that by double clicking on the drawings in the Word version of this procedure, the Visio 2000 files can be accessed and the drawings reused as per the *metered market participant’s/metering service provider’s* need.

SLDs must be accompanied by completed IMO-FORM-1043 “Conceptual Drawing Review Submission Form” (available on the *IESO* Web site).

Submission to IESO:

The SLD and IMO-FORM-1043 may be submitted to the *IESO* by email to customer.relations@ieso.ca, Attention: Metering Installations.

These documents can also be submitted to the *IESO* by mail, courier or fax according to instructions on IMO-FORM-1043.

Upon receipt of the SLD and the accompanying “CDR-Submission Form”, the *IESO* will email a confirmation of receipt.

The *IESO* will not review, and will return to the submitting person, an SLD that does not comply with the requirements of Section 1.6 or that is not accompanied or followed by a duly completed and signed “CDR-Submission Form”.

1.6 Required Information for SLD Submission

Table 1-1 below lists relevant information that may be included on the SLDs submitted for CDR.

Since the SLDs presented as examples in Appendix B must also be submitted in support of registering a *metering installation* in the *IESO-administered market* (see “Market Manual 3: Metering, Part 3.2: Meter Point Registration and Maintenance”), relevant specific items required for SLDs in each of the two situations are specified.

Table 1-1: SLD information

Item #	Description	SLD for		Comments
		CDR	MI Reg.	
1	<i>Facility type and name/location</i>	x	x	- Specify type: TS, DS, PME etc - Provide precise civic address/geographic location - or GPS co-ordinates - If embedded, add to the name: “(embedded of [Station Name])”
2	<i>Delivery Point ID(s) (energy, network and connection, as applicable)</i>		x	Delivery Point ID’s in CDMS
3	<i>Defined meter point(s)</i>		x	Defined Meter Point (DMP) in CDMS
4	<i>Location of meters</i>	x	x	<i>Metered market participant/metering service provider</i> required to show only the <i>meters</i> for which they are responsible
5	<i>Meter point IDs</i>	if known	if known	For new <i>Metering Installations IESO</i> will provide IDs
6	<i>Embedded Connection Point(s) to distributor (LDC)</i>	x	x	Provide precise info about ECP to <i>distributor (LDC)</i> : - pole # and civic address/geographic location , or - GPS co-ordinates
7	<i>Distance from Metering Installation to IESO-controlled grid (in meters)</i>	x	x	Only for the first <i>meter(s)</i> downstream from the grid
8	<i>Location of current transformers (CTs) and voltage transformers (VTs)</i>	x	x	Correct representation of CT and VT (CVT).
9	<i>Distance between the connection points of CTs and VTs (in meters)</i>		x	CTs’ polarity orientation should be indicated
10	<i>Number of CTs and VTs for each metering installation</i>	x	x	VT's connection type should be indicated.
11	<i>CT and VT ratios available and continuous current rating factor (RF) for CT's.</i>	x	x	

Item #	Description	SLD for		Comments
		CDR	MI Reg.	
12	CT and VT ANSI class for each Measurement Canada Approved ratio and their Notices of Approval numbers.	x	x	
13	CT and VT ratios as proposed or as in use	x	x	
14	Location and designation of power and <i>station service</i> transformers, breakers, <i>disconnect</i> switches, racking mechanisms, pull-out drawers and VT fuses	x	x	Breakers and <i>disconnect</i> switches should indicate normal operating status
15	Source of auxiliary power for each <i>meter</i> .	x	x	If internally powered please indicate from which phase.
16	Power/ <i>Station Service</i> transformer nameplate rating including: <ul style="list-style-type: none"> • Cooling rating; • MVA/kVA rating; • Tap changer arrangement (for power transformers, only); • Voltages; • Connection type (wye, delta, etc.); Grounding	x	x	Include the size of grounding impedance if applicable.
17	Limits of <i>metered market participant</i> responsibility with regard to the <i>metering installation</i>	x	x	
18	<i>Metering installation</i> status with regard to Blondel compliance	x	x	If Non-Blondel compliant list the category as per Wholesale Revenue Metering Standard - Hardware (MDP-STD-0004) Section 4.3.3
19	<i>Metering installation</i> status with regard to Power Switching.	x	x	MI meets all requirements as per Wholesale Revenue Metering Standard - Hardware (MDP-STD-0004) Section 6.7.

Item #	Description	SLD for		Comments
		CDR	MI Reg.	
20	<p><i>Generator nameplate information including:</i></p> <ul style="list-style-type: none"> • <i>MVA/kVA rating</i> • <i>Output voltage</i> • <i>Connection type (wye, delta, etc.)</i> • <i>Operating nomenclature (i.e. G1, G2,)</i> <p><i>Grounding</i></p>	x	x	<p>Include the size of grounding impedance if applicable.</p> <p>Where multiple identical generators are installed (i.e. such as in a typical Wind Farm application) show all details for a single generator and confirm total number of generators connected.</p>
21	<p>Indicate the <i>metering installation</i> conforming status: Declaration of Compliance (DOC) or the Alternative Metering Installation Standard (AMIS).</p>	x	x	<p>Indicate if the metering installation meets the DOC or AMIS standard.</p>

1.7 Disclaimer for IESO Review of Conceptual Drawings of Metering Installations

Review by the *IESO* of conceptual drawings for proposed *metering installations* or for a proposed change to equipment, parameters or settings within a *metering installation* is provided to *metered market participants* and *metering service providers* as a convenience only. The *IESO* does not represent or warrant by contracting such reviews or through any feedback it gives to *metered market participants* or *metering service providers* as a result of such reviews, that the conceptual drawings or the subject-matter to which they pertain are accurate, complete, adequate or in compliance with applicable provisions of the *market rules* or of any policy or standard established by the *IESO*, or that the subject *metering installation* or proposed changes to equipment, parameters or settings within a *metering installation* will be registered by the *IESO*.

Metered market participants and *metering service providers* are solely responsible for ensuring that their *metering installations*, or proposed changes to equipment, parameters or settings within their *metering installations*, comply in all respects with the applicable provisions of the *market rules* and of any policy or standard established by the *IESO* pursuant to the *market rules*.

For greater certainty, notwithstanding the outcome of the *IESO's* review of conceptual drawings submitted by a *metered market participant* or a *metering service provider*, the *IESO* reserves the absolute right to:

- Refuse registration of a *metering installation* or refuse authorization of a proposed change to equipment, parameters or settings within a *metering installation* that is, or was, the subject of a CDR in the event of non-compliance with the *market rules* or any policies or standards established by the *IESO*; and

- Take such other action as may be permitted by the *market rules* in respect of non-compliant *metering installations* or non-compliant changes to equipment, parameters or settings within a *metering installation*.

1.8 Contact Information

If the *market participant* wishes to contact the *IESO*, the *market participant* can contact the *IESO* Customer Relations via email at <mailto:customer.relations@ieso.ca> or via telephone, mail or courier to the numbers and addresses given on the *IESO* Web site (www.ieso.ca - or click on 'Have a question?' to go to the 'Contacting the IESO' page). If the *IESO* Customer Relations is closed, telephone messages or emails may be left in relevant voice or electronic *IESO* mail boxes, which will be answered as soon as possible by Customer Relations staff.

Standard forms that *market participants* must complete for this procedure are listed in Appendix A. These forms are generally available for downloading on the *IESO* Web site. These signed forms as well as the accompanying supporting documentation must be transmitted to the *IESO* via mail or courier by using the appropriate address provided on the *IESO* Web site or on the form. All correspondence relating to this procedure shall identify the subject: **Conceptual Drawing Review**.

– End of Section –

2. Procedural Work Flow

The following diagram represents the flow of work and information related to CDR among the *IESO*, the primary external *market participant* involved in the procedure, and any other parties.

The steps illustrated in the diagram are described in detail in Section 3.

Table 2–1: Legend for Procedural Work Flow Diagrams

Legend	Description
Oval	An event that triggers task or that completes task. Trigger events and completion events are numbered sequentially within procedure (01 to 99).
Task Box	Shows reference number, party responsible for performing task (if “other party”), and task name or brief summary of task. Reference number (e.g., 1A.02) indicates procedure number within current <i>market manual</i> (1), sub-procedure identifier (if applicable) (A), and task number (02).
Solid horizontal line	Shows information flow between the <i>IESO</i> and external parties.
Solid vertical line	Shows linkage between tasks.
Broken line	Links trigger events and completion events to preceding or succeeding task.

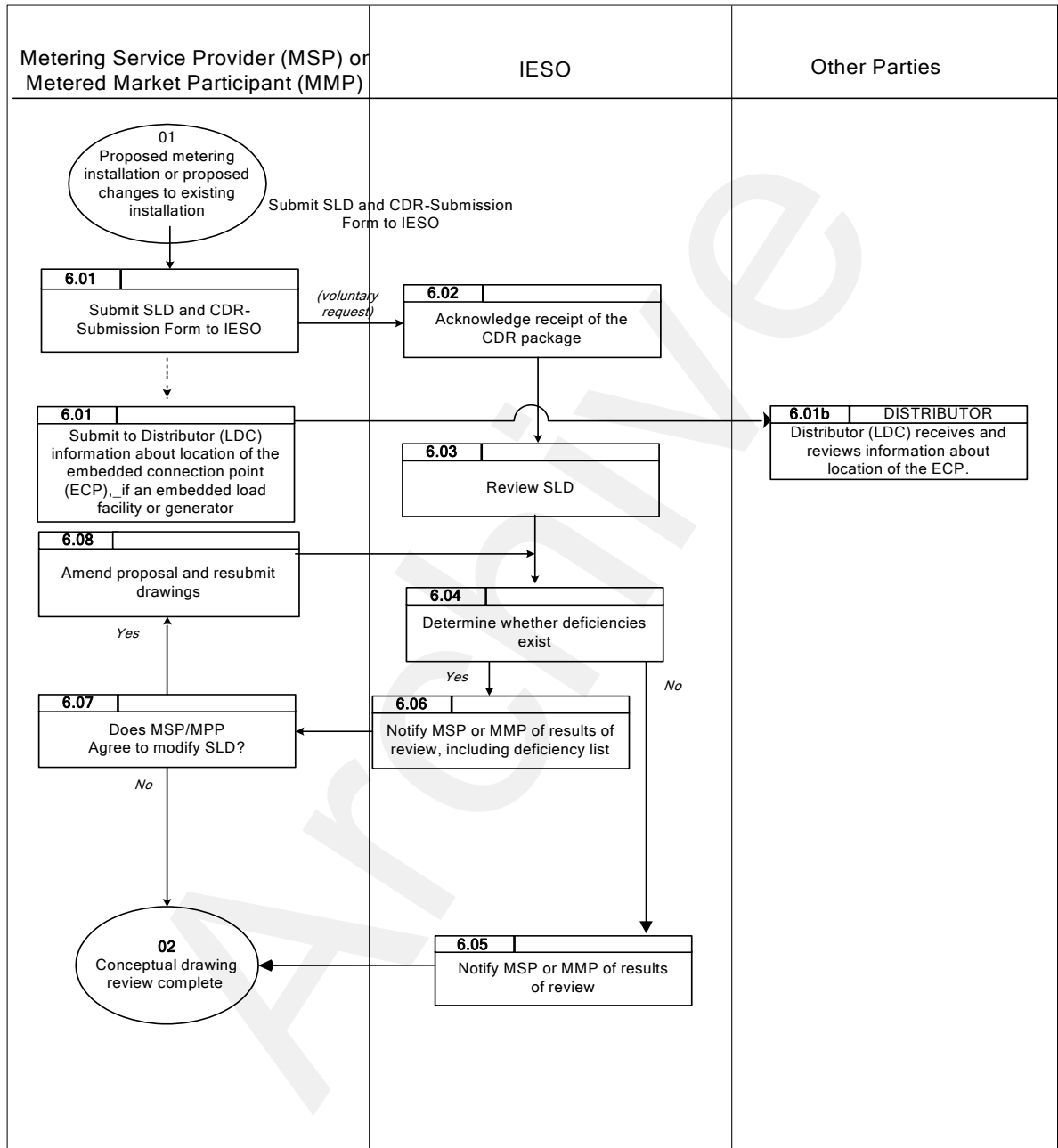

Figure 2-1: Procedural Work Flow for Conceptual Drawing Review

- End of Section -

3. Procedural Steps

This section contains detail on the tasks (steps) that comprise the conceptual drawing review procedure. The table contains seven columns, as follows:

Ref

The numerical reference to the task.

Task name

The task name as identified in Section 2.

Task detail

Detail about the task.

When

A list of all the events that can trigger commencement of the task.

Resulting information

A list of the information flows that may or must result from the task.

Method

The format and method for each information flow are specified.

Completion events

A list of all the circumstances in which the task should be deemed finished.

Table 3-1: Procedural Steps for Conceptual Drawing Review

Ref.	Task Name	Task Detail	When	Resulting Information	Method	Completion Events
01	<i>Metering installation or changes to an existing metering installation proposed by metering service provider or metered market participant.</i>	Conceptual drawings required with proposal.	Triggering event.			
6.01	Submit SLD and “CDR-Submission Form” to IESO.	<i>Metering service provider or metered market participant completes a “CDR-Submission Form” and forwards the “CDR-Submission Form” with the SLD in prescribed format to the IESO.</i>	Following completion of SLD of proposed <i>metering installation</i> or of proposed change to existing <i>metering installation</i> .		Email, mail, courier or fax. SLD as a Visio file.	
6.01a	Submit to <i>Distributor</i> (LDC) information about location of the <i>embedded connection point</i> (ECP), if an <i>embedded load facility</i> or <i>generator</i> .	The <i>metering service provider</i> informs the <i>Distributor</i> (LDC) the precise location of the point of connection between the <i>embedded load facility</i> or <i>generator</i> and the <i>distribution system</i> . The details of the ECP – pole number and civic address / geographic location, or GPS coordinates– will be as shown on the SLD submitted to the IESO.	After step 6.01.	Notification in writing by the <i>metering service provider</i> to the <i>Distributor</i> (LDC).	Fax, mail or courier.	The <i>Distributor</i> (LDC) receives precise information about the location of the ECP.
6.01b	<i>Distributor</i> (LDC) receives and reviews information about location of the ECP.	<i>Distributor</i> (LDC) reviews information about location of ECP being submitted by the <i>metering service provider</i> to the IESO on SLD for registration of the <i>embedded facility</i> .	After step 6.01a.	Location of ECP communicated to <i>Distributor</i> (LDC).	Fax, mail or courier.	<i>Distributor</i> (LDC) contacts the MMP re: any issue about ECP location.

Table 3-1: Procedural Steps for Conceptual Drawing Review

Ref.	Task Name	Task Detail	When	Resulting Information	Method	Completion Events
6.02	Acknowledge receipt.	The <i>IESO</i> sends acknowledgement of receipt of drawing package to <i>metering service provider</i> or <i>metered market participant</i> .	Upon receipt of SLD and “CDR-Submission Form” by the <i>IESO</i> .		Email.	
6.03	Review SLD.	The <i>IESO</i> reviews SLD relative to the <i>market rules</i> and applicable <i>IESO</i> standards and policies.				
6.04	Determine whether deficiencies exist regarding the proposed installation or the proposed changes to the existing installation.	The <i>IESO</i> reviews the submission and assesses whether the SLD indicates any deficiencies in the proposed installation or the proposed changes to the existing installation. If “no”, proceed to step 6.05. If “yes”, skip to step 6.06.				
6.05	Notify <i>metering service provider</i> or <i>metered market participant</i> of results of review.	If the <i>IESO</i> determines that the SLD contains no significant deficiencies from the <i>market rules</i> , the <i>IESO</i> sends a notification to the <i>metering service provider</i> or <i>metered market participant</i> to that effect.		Notification of results of review.	Fax or email.	Completion of CDR.

Table 3-1: Procedural Steps for Conceptual Drawing Review

Ref.	Task Name	Task Detail	When	Resulting Information	Method	Completion Events
6.06	Notify <i>metering service provider</i> or <i>metered market participant</i> of results of review.	If the <i>IESO</i> determines that the SLD does contain significant deficiencies from the <i>market rules</i> , the <i>IESO</i> sends a notification to the <i>metering service provider</i> or <i>metered market participant</i> to that effect.		Notification of results of review, including list of deficiencies.	Fax or email.	
6.07	Does <i>metering service provider</i> or <i>metered market participant</i> agree to modify the SLD?	Review list of deficiencies.		Yes		Modify SLD and re-submit.
				No		Completion of CDR.
6.08	Amend proposal and re-submit to <i>IESO</i> .	If <i>metering service provider</i> or <i>metered market participant</i> agrees with <i>IESO's</i> review, the <i>metering service provider</i> or <i>metered market participant</i> may re-submit the modified SLD.			Email or regular mail.	

– End of Section –

Archive

Appendix A: Forms

This appendix contains a list of the forms associated with the procedure for Conceptual Drawing Review, which are available on the *metering* page of the *IESO* Web site (<http://www.ieso.ca/iesoweb/metering/metering.asp>). The forms included are as follows:

Form Name	Form Number
Conceptual Drawing Review Submission Form	IMO-FORM-1043

– End of Section –

Archive

Appendix B: Illustrative Examples of Typical Concept Drawings

B.1 Transformer Station

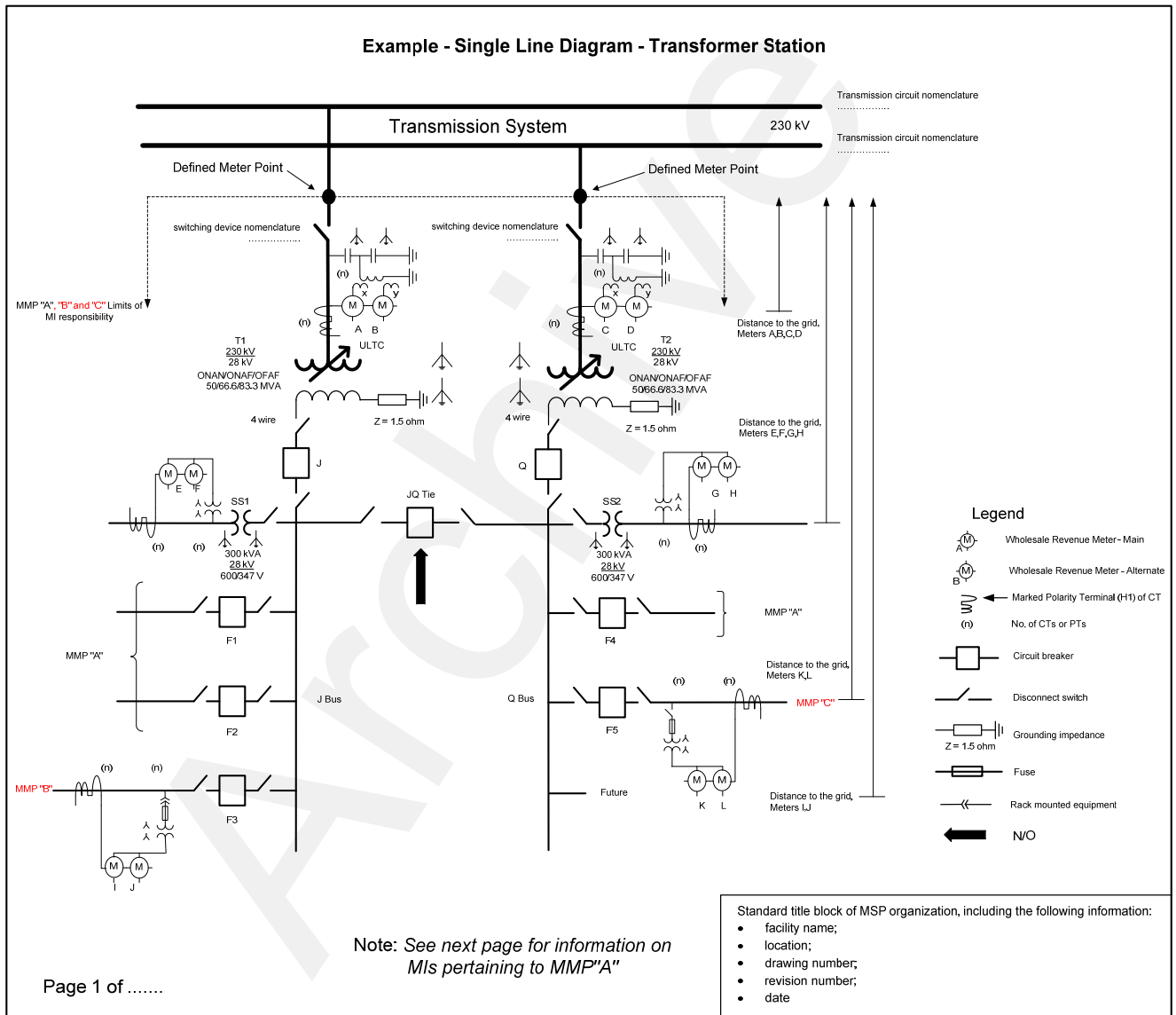

Figure B-1: SLD for a Transformer Station

Metering Installation Data	Metering Installation Data
Meter Point IDs	Meter Point IDs
A	C
B	D
Aux PWR	Aux PWR
ULTC range (+/-%).....	ULTC range (+/-%).....
CT:	CT:
MC NOA#.....	MC NOA#.....
RF.....	RF.....
Ratios:	Ratios:
Available MC Approved ANSI Class In use	Available MC Approved ANSI Class In use
.....
.....
.....
.....
PT:	PT:
MC NOA#.....	MC NOA#.....
Ratios:	Ratios:
Available MC Approved ANSI Class In use	Available MC Approved ANSI Class In use
.....
.....
.....
.....
Distance to the gridm	Distance to the gridm
Distance between CTs and PTsm	Distance between CTs and PTsm
Defined Meter Point ID (common).....	Defined Meter Point ID (common).....
Delivery Point ID (common)*	Delivery Point ID (common)*
Energy.....	Energy.....
Network.....	Network.....
Connection.....	Connection.....
Is MI Blondel compliant (Y/N)?	Is MI Blondel compliant (Y/N)?
If Not - Section 4.3.3	If Not - Section 4.3.3
Is MI subject to Power Switching (Y/N)?	Is MI subject to Power Switching (Y/N)?
DOC or AMIS? (circle one)	DOC or AMIS? (circle one)
<p>Note: This information regards only MIs pertaining to MMP"A"</p> <p>Page 2 of.....</p>	<p>Standard title block of MSP organization, including the following information:</p> <ul style="list-style-type: none"> • facility name; • location; • drawing number; • revision number; • date

Figure B-1: SLD for a Transformer Station (continued)

References

Document ID	Document Title
MDP_RUL_0002	Market Rules
MDP_STD_0004	Wholesale Revenue Metering Standard—Hardware
MDP_PRO_0013	Market Manual 3: Metering, Part 3.2: Meter Point Registration and Maintenance
MDP_MAN_0003	Market Manual 3: Metering, Part 3.0: Metering Overview

– End of Document –