

# **BRONTE SUB-REGION INTEGRATED REGIONAL RESOURCE PLAN**

Part of the Burlington-Nanticoke Planning Region | Revised April 27, 2017  
(originally issued June 30, 2016)



# **Integrated Regional Resource Plan**

## **Bronte Sub-region**

This Integrated Regional Resource Plan (“IRRP”) was prepared by the Independent Electricity System Operator (“IESO”) pursuant to the terms of its Ontario Energy Board licence, EI-2013-0066.

The IESO prepared the IRRP on behalf of the Bronte Sub-Region Working Group (the “Working Group”), which included the following members:

- Independent Electricity System Operator
- Oakville Hydro Electricity Distribution Inc.
- Burlington Hydro Inc.
- Hydro One Networks Inc. (Transmission)

The Working Group assessed the adequacy of electricity supply to customers in the Bronte Sub-region over a 20-year period; developed a flexible, comprehensive, integrated plan that considers opportunities for coordination in anticipation of potential demand growth scenarios and varying supply conditions in the Bronte Sub-region and developed an implementation plan for the recommended options, while maintaining flexibility in order to accommodate changes in key conditions over time.

The Working Group members agree with the IRRP’s recommendations and support implementation of the plan through the recommended actions, subject to obtaining all necessary regulatory and other approvals.

# Table of Contents

- 1. Introduction.....1**
- 2. The Integrated Regional Resource Plan.....3**
  - 2.1 Near-Term and Medium-Term Plan (2015 through 2024).....4
  - 2.2 Longer-Term Plan (2025-2034).....6
- 3. Development of the IRRP .....7**
  - 3.1 The Regional Planning Process .....7
  - 3.2 The IESO’s Approach to Regional Planning.....10
  - 3.3 Bronte Sub-region Working Group and IRRP Development.....11
- 4. Background and Study Scope .....13**
  - 4.1 Study Scope .....13
  - 4.2 Bulk Transmission System Study .....15
- 5. Demand Forecast .....17**
  - 5.1 Historical Demand .....17
  - 5.2 Demand Forecast Methodology .....19
  - 5.3 Gross Demand Forecast.....21
  - 5.4 Conservation Assumed in the Forecast.....22
  - 5.5 Distributed Generation Assumed in the Forecast.....24
  - 5.6 Planning Forecasts.....24
- 6. Needs .....26**
  - 6.1 Needs Assessment Methodology .....26
  - 6.2 Needs.....27
    - 6.2.1 Overload of B7/B8.....28
    - 6.2.2 Bronte TS – Post Contingency Voltage Drop .....28
    - 6.2.3 Cumberland TS – Power Factor .....29
    - 6.2.4 Oakville TS #2 – Capacitor Bank Operation.....29
    - 6.2.5 Restoration Needs.....30
  - 6.3 Needs Summary .....34
- 7. Near- and Medium-Term Plan.....37**
  - 7.1 Alternatives for Meeting Near- and Medium-Term Needs .....37
    - 7.1.1 Conservation.....37

7.1.2	Local Generation.....	39
7.1.3	Transmission and Distribution .....	41
7.2	Recommended Near- and Medium-Term Plan.....	47
7.3	Implementation of Near- and Medium-Term Plan .....	48
<b>8.</b>	<b>Long-Term Plan .....</b>	<b>49</b>
<b>9.</b>	<b>Engagement Activities.....</b>	<b>51</b>
<b>10.</b>	<b>Conclusion .....</b>	<b>52</b>

**List of Figures**

Figure 1-1: Map of Bronte Sub-region..... 1

Figure 2-1: Conceptual Layout of Options for Bronte Need..... 5

Figure 3-1: Levels of Electricity System Planning ..... 9

Figure 3-2: Steps in the IRRP Process ..... 11

Figure 4-1: Regional Transmission Facilities..... 14

Figure 4-2: Bronte Sub-region Electrical Sub-systems ..... 15

Figure 5-1: Historical Peak Demand in the Bronte Sub-region ..... 18

Figure 5-2: Historical Peak Demand in the Bronte Sub-region, Gross and Net..... 19

Figure 5-3: Development of Demand Forecast ..... 20

Figure 5-4: Bronte Sub-region Gross Forecast..... 21

Figure 5-5: Categories of Conservation Savings..... 22

Figure 6-1: ORTAC Load Restoration Criteria..... 31

Figure 6-2: Restoration Pocket for T38/39B ..... 32

Figure 6-3: Restoration Pocket for Southwest GTA, West of Cooksville ..... 33

Figure 6-4: Loading Limits on Bronte TS, Multiple Constraints, for Loss of B7 ..... 35

Figure 7-1: Effect of Conservation Targets on Bronte TS Peak Load ..... 38

**List of Tables**

Table 5-1: Peak Demand MW Savings from 2013 LTEP Conservation Targets, Select Years ..... 23

Table 6-1: Peak Load and Restoration Requirements for West of Cooksville Pocket ..... 33

Table 6-2: Summary of Needs in Bronte Sub-region..... 36

Table 7-1: Summary of Wires Options to Address Bronte Capacity Need ..... 44

Table 7-2: Summary of Needs and Recommended Actions in Bronte Sub-region..... 48

**List of Appendices**

- Appendix A: Demand Forecast
- Appendix B: Needs Assessment

## List of Abbreviations

Abbreviations	Descriptions
A	Amp
ACSR	Aluminum Conductor, Steel Reinforced
Burlington Hydro or BHI	Burlington Hydro Inc.
CCRA	Connection Cost Recovery Agreement
CDM or Conservation	Conservation and Demand Management
CFF	Conservation First Framework
CHP	Combined Heat and Power
DG	Distributed Generation
DR	Demand Response
DSP	Distribution System Plan
Enersource	Enersource Hydro Mississauga Inc. (now Alectra Utilities Corporation)
FIT	Feed-in Tariff
GTA	Greater Toronto Area
Haldimand Power	Haldimand County Power Inc. (now Hydro One Distribution)
HHH	Halton Hills Hydro Inc.
Hydro One	Hydro One Networks Inc.
IAP	Industrial Accelerator Program
IESO	Independent Electricity System Operator
IRRP	Integrated Regional Resource Plan
kV	Kilovolt
LAC	Local Advisory Committee
LDC	Local Distribution Company
LMC	Load Meeting Capability
LTEP	(2013) Long-Term Energy Plan

Abbreviations	Descriptions
LTR	Limited Time Rating
MCOB	Maximum Commercial Operation Date
MTS	Municipal Transformer Station
MW	Megawatt
Norfolk Power	Norfolk Power Distribution Inc. (now Hydro One Distribution)
NWGTA	North West Greater Toronto Area
Oakville Hydro	Oakville Hydro Electricity Distribution Inc.
OEB or Board	Ontario Energy Board
OPA	Ontario Power Authority
ORTAC	Ontario Resource and Transmission Assessment Criteria
Pickering NGS	Pickering Nuclear Generation Station
PPWG	Planning Process Working Group
PPWG Report	Planning Process Working Group Report to the Board
QEW	Queen Elizabeth Way
RIP	Regional Infrastructure Plan
SS	Switching Station
TOU	Time-of-Use
TS	Transformer Station
TWh	Terawatt-Hours
Working Group	Technical Working Group for Bronte Sub-region IRRP



# 1. Introduction

This Integrated Regional Resource Plan (“IRRP”) addresses the electricity needs for the Bronte Sub-region over the next 20 years. This report was prepared by the Independent Electricity System Operator (“IESO”) on behalf of the Technical Working Group composed of the IESO, Oakville Hydro Electricity Distribution Inc. (“Oakville Hydro”), Burlington Hydro Inc. (“Burlington Hydro”) and Hydro One Transmission (the “Working Group”).

The Bronte Sub-region is within the Burlington-Nanticoke planning region. In municipal terms, it roughly encompasses the cities of Burlington and Oakville. The study is focused on the area served by Bronte Transformer Station (“TS”), but the scope will also include consideration of the broader Burlington Hydro and Oakville Hydro service territories, which include portions of the Greater Toronto Area (“GTA”) West planning region. Bronte TS is radially supplied from the double-circuit 115 kV transmission line B7/B8 originating from Burlington TS. The study area, including all area transformer stations, is shown in Figure 1-1.

**Figure 1-1: Map of Bronte Sub-region**

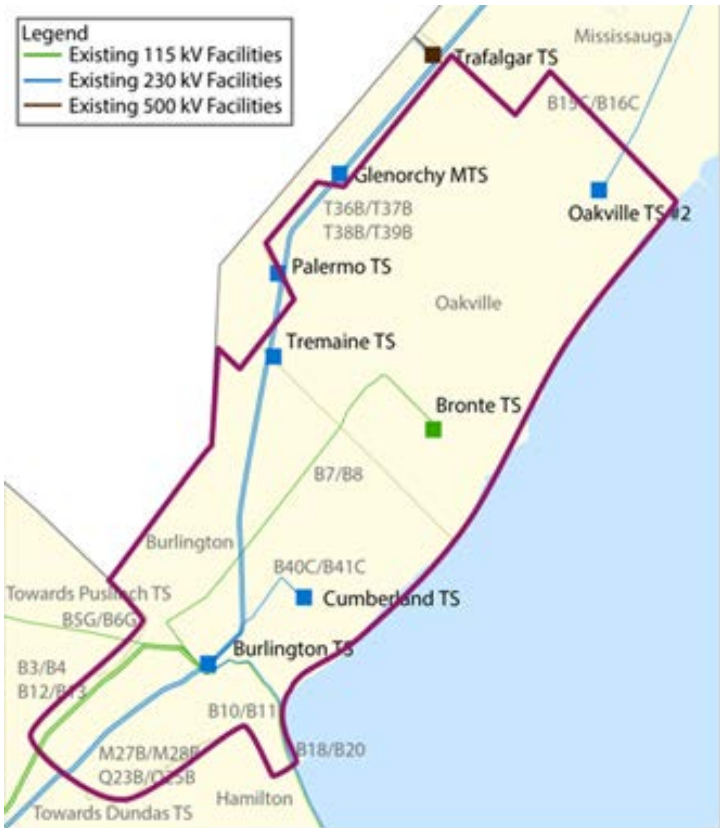

In Ontario, planning to meet the electrical supply and reliability needs of a large area or region is done through regional electricity planning, a process that was formalized by the Ontario Energy Board (“OEB” or “Board”) in 2013. In accordance with the OEB regional planning process, transmitters, distributors and the IESO are required to carry out regional planning activities for 21 electricity planning regions at least once every five years.

This IRRP identifies power system capacity and reliability requirements, and coordinates the options to meet customer needs in the sub-region over the next 20 years. Specifically, this IRRP identifies investments for immediate implementation necessary to meet near- and medium-term needs in the sub-region, respecting the lead time for development.

This IRRP also identifies options to meet long-term needs, but given forecast uncertainty, the longer development lead time and the potential for technological change, the plan maintains flexibility for long-term options and does not recommend specific projects at this time. Instead, the long-term plan identifies near-term actions to consider and develop alternatives, engage with the community and gather information and lay the groundwork for future options. These actions are intended to be completed before the next IRRP cycle, scheduled for 2020 or sooner, depending on demand growth, so that the results can inform decisions should any decisions need to be made at that time.

This report is organized as follows:

- A summary of the recommended plan for the Bronte Sub-region is provided in Section 2;
- The process and methodology used to develop the plan are discussed in Section 3;
- The context for electricity planning in the Bronte Sub-region and the study scope are discussed in Section 4;
- Demand forecast scenarios, and conservation and distributed generation (“DG”) assumptions, are described in Section 5;
- Electricity needs in the Bronte Sub-region are presented in Section 6;
- Alternatives and recommendations for meeting needs are addressed in Sections 7 and 8;
- A summary of engagement to date and moving forward is provided in Section 9; and
- A conclusion is provided in Section 10.

## 2. The Integrated Regional Resource Plan

The Bronte Sub-region IRRP provides recommendations to address the sub-region's forecast electricity needs over the next 20 years, based on the application of the IESO's Ontario Resource and Transmission Assessment Criteria ("ORTAC"). This IRRP identifies forecast electricity needs in the sub-region over the near term (0-5 years, or 2015 through 2019), medium term (6-10 years, or 2020 through 2024) and longer term (11- 20 years, or 2025 through 2034). These planning horizons are distinguished in the IRRP to reflect the different levels of forecast certainty, lead time for development and planning commitment required over these time horizons. The IRRP was developed based on consideration of planning criteria, including reliability, cost, feasibility, and maximization of the use of the existing electricity system, where it is economic to do so.

This IRRP identifies and recommends specific projects for implementation in the near term. This is necessary to ensure that they are in-service in time to address the area's more urgent needs, respecting the shorter lead time for development of the recommended projects or actions. This IRRP also identifies possible longer-term electricity needs. However, as these needs are forecast to arise in the future, it is not necessary, nor would it be prudent given forecast uncertainty and the potential for technological change to recommend specific projects at this time. Instead, near-term actions are identified to gather information and lay the groundwork for future options. These actions are intended to be completed before the next IRRP cycle so that their results can inform further discussion at that time.

## 2.1 Near-Term and Medium-Term Plan (2015 through 2024)

By 2018, peak summer electrical demand on Bronte TS is expected to exceed 135 MW, triggering overloads on the supplying B7/B8 circuits following the loss of the companion circuit. This is due to forecast load growth in the Oakville Hydro service area supplied by Bronte TS. By 2021, forecast station loading is expected to exceed the maximum 10% post contingency voltage drop criteria; although it may be possible to delay this occurrence by as much as 10 years by better distributing load between buses. Since both of these needs are the direct result of loading on Bronte TS, the near-term plan considered options to maintain total load below 135 MW.

Three near-term options were identified, each capable of meeting near- and medium-term needs:

1. Upgrade transmission line supplying Bronte TS, and redistribute loads between buses
2. Transfer one feeder of load from Bronte TS to Tremaine TS
3. Maintain existing peak demand at Bronte TS to 135 MW through incremental load transfers as required from Bronte TS to other transformer stations serving Oakville Hydro's franchise territory

These options are shown conceptually on the map below:

### Near/Medium-Term Needs and Plan

- Thermal loading of B7/B8 exceeds capacity following loss of companion circuit due to forecast load growth in Oakville Hydro's service area supplied by Bronte TS – 2018
- Post contingency voltage drop exceeds 10% at Bronte TS – 2021
- Address both needs by limiting max load at Bronte TS to 135 MW by transferring load (as required) from Bronte TS to other stations in Oakville Hydro's franchise territory – 2018 onwards
- Details of implementation to be developed by the LDCs.

**Figure 2-1: Conceptual Layout of Options for Bronte Need**

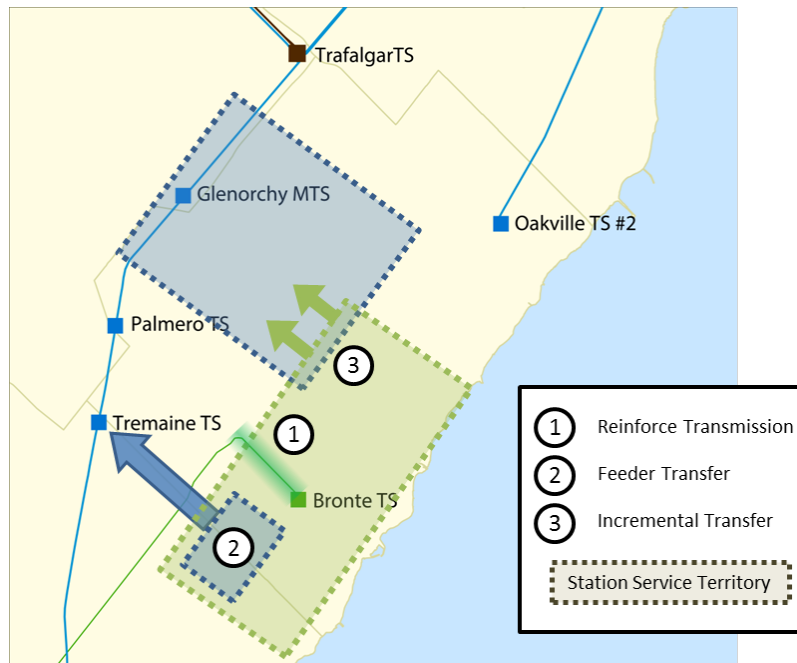

## Recommended Actions

- 1. Maintain existing peak demand at Bronte TS to 135 MW through incremental load transfers (as required) from Bronte TS to other transformer stations serving Oakville Hydro's franchise territory**

Oakville Hydro can maintain peak load levels at Bronte TS to 135 MW by making incremental load transfers (as required) to other transformer stations serving its franchise territory. These transfers will enable the anticipated 15 MW of new customer demand to be supplied from neighbouring stations, primarily Glenorchy MTS. Unlike a feeder transfer, load will not be removed from Bronte TS in one large chunk. Instead, smaller amounts of load will be periodically transferred as required, particularly as new customers are connected and related new distribution infrastructure becomes available to leverage. In addition to providing incremental capacity on the constraining transmission line supplying Bronte TS, this approach offers additional benefits to customer reliability by enabling new supply paths and configurations to respond to planned and forced outages. Oakville Hydro has indicated that the cost of these actions will be less over time than the estimated \$3 million for the next preferred option of a feeder transfer (see below).

If incremental load growth cannot be managed through incremental load transfers, an alternate solution would be required. The technically feasible and next lowest cost option for reducing load at Bronte TS is to transfer a full feeder (15 MW) to an adjacent station. This can be accomplished by constructing additional distribution infrastructure to enable either temporary or permanent connections between the service areas of Bronte TS and a nearby station (Tremaine TS). Both Burlington Hydro and Oakville Hydro have indicated that it would be technically feasible to construct 27.6 kV connection facilities between Tremaine TS and the Bronte TS service areas to enable a full feeder transfer. Costs range from approximately \$4 million to \$5 million, significantly less than the estimated \$9.7 million for the remaining transmission solution. The transmission solution entails upgrading the limiting section of B7/B8 circuits supplying Bronte TS, which would enable approximately 15 MW of incremental capacity to be served, with appropriate load balancing at the station.

## **2.2 Longer-Term Plan (2025-2034)**

If higher than anticipated load growth materializes in the long term, measures such as incremental DG or demand response (“DR”) programs may become effective options to defer future infrastructure investment. These options will be considered during future regional planning studies when the nature of the long-term needs, alternatives, and associated costs become clearer. In the meantime, Working Group members will continue to engage with local planning bodies to participate in and coordinate with community planning initiatives and identify cost effective opportunities for supplying local energy needs.

In the event that long-term load growth exceeds system capabilities after cost effective CDM and DG is pursued, an alternative wires infrastructure solution may be required to serve incremental demand. Given the high expected cost of a transmission based solution, it is anticipated that a distribution transfer to a nearby station will remain the most cost effective solution, but an assessment will be required closer to the need date to determine feasibility and cost as changes to system configurations may occur.

## 3. Development of the IRRP

### 3.1 The Regional Planning Process

In Ontario, planning to meet the electricity needs of customers at a regional level is done through regional planning. Regional planning assesses the interrelated needs of a region—defined by common electricity supply infrastructure—over the near, medium, and long term and develops a plan to ensure cost-effective, reliable electricity supply. Regional plans consider the existing electricity infrastructure in an area, forecast growth and customer reliability, evaluate options for addressing needs, and recommend actions.

Regional planning has been conducted on an as needed basis in Ontario for many years. Most recently, the former Ontario Power Authority (“OPA”) carried out planning activities to address regional electricity supply needs. The OPA conducted joint regional planning studies with distributors, transmitters, the IESO and other stakeholders in regions where a need for coordinated regional planning had been identified.

In the fall of 2012, the Board convened a Planning Process Working Group (“PPWG”) to develop a more structured, transparent, and systematic regional planning process. This group was composed of industry stakeholders including electricity agencies, utilities, and stakeholders, and in May 2013, the PPWG released its report to the Board<sup>1</sup> (“PPWG Report”), setting out the new regional planning process. Twenty-one electricity planning regions were identified in the PPWG Report, and a phased schedule for completion was outlined. The Board endorsed the PPWG Report and formalized the process timelines through changes to the Transmission System Code and Distribution System Code in August 2013, as well as through changes to the OPA’s licence in October 2013. The OPA’s licence changes required it to lead a number of aspects of regional planning. After the merger of the IESO and the OPA on January 1, 2015, the regional planning responsibilities identified in the OPA’s licence were transferred to the IESO.

The regional planning process begins with a Needs Screening process performed by the transmitter, which determines whether there are needs requiring regional coordination. If regional planning is required, the IESO then conducts a Scoping Assessment to determine whether a comprehensive IRRP is required, which considers conservation, generation,

---

<sup>1</sup> [http://www.ontarioenergyboard.ca/OEB/Documents/EB-2011-0043/PPWG\\_Regional\\_Planning\\_Report\\_to\\_the\\_Board\\_App.pdf](http://www.ontarioenergyboard.ca/OEB/Documents/EB-2011-0043/PPWG_Regional_Planning_Report_to_the_Board_App.pdf)

transmission, and distribution solutions, or whether a more limited “wires” solution is the preferable option such that a transmission and distribution focused Regional Infrastructure Plan (“RIP”) can be undertaken instead. The Scoping Assessment determines what type of planning is required for each region. There may also be regions where infrastructure investments do not require regional coordination and so can be planned directly by the distributor and transmitter outside of the regional planning process. At the conclusion of the Scoping Assessment, the IESO produces a report that includes the results of the Needs Screening process and a preliminary Terms of Reference. If an IRRP is the identified outcome, the IESO is required to complete the IRRP within 18 months. If an RIP is the identified outcome, the transmitter takes the lead and has six months to complete it. Both RIPs and IRRPs are to be updated at least every five years. The draft Scoping Assessment Outcome Report is posted to the IESO’s website for a 2-week comment period prior to finalization.

The final IRRPs and RIPs are posted on the IESO’s and relevant transmitter’s websites, and may be referenced and submitted to the Board as supporting evidence in rate or “Leave to Construct” applications for specific infrastructure investments. These documents are also useful for municipalities, First Nation communities and Métis community councils for planning, conservation and energy management purposes, as information for individual large customers that may be involved in the region, and for other parties seeking an understanding of local electricity growth, CDM and infrastructure requirements. Regional planning is not the only type of electricity planning that is undertaken in Ontario. As shown in Figure 3-1, there are three levels of planning that are carried out for the electricity system in Ontario:

- Bulk system planning
- Regional system planning
- Distribution system planning

Planning at the bulk system level typically considers the 230 kV and 500 kV network and examines province-wide system issues. Bulk system planning considers not only the major transmission facilities or “wires”, but it also assesses the resources needed to adequately supply the province. This type of planning is typically carried out by the IESO pursuant to government policy. Distribution planning, which is carried out by Local Distribution Companies (“LDCs”), considers specific investments in an LDC’s territory at distribution level voltages.

Regional planning can overlap with bulk system planning. For example, overlaps can occur at interface points where there may be regional resource options to address a bulk system issue.



Similarly, regional planning can overlap with the distribution planning of LDCs. For example, overlaps can occur when a distribution solution addresses the needs of the broader local area or region. Therefore, it is important for regional planning to be coordinated with both bulk and distribution system planning as it is the link between all levels of planning.

**Figure 3-1: Levels of Electricity System Planning**

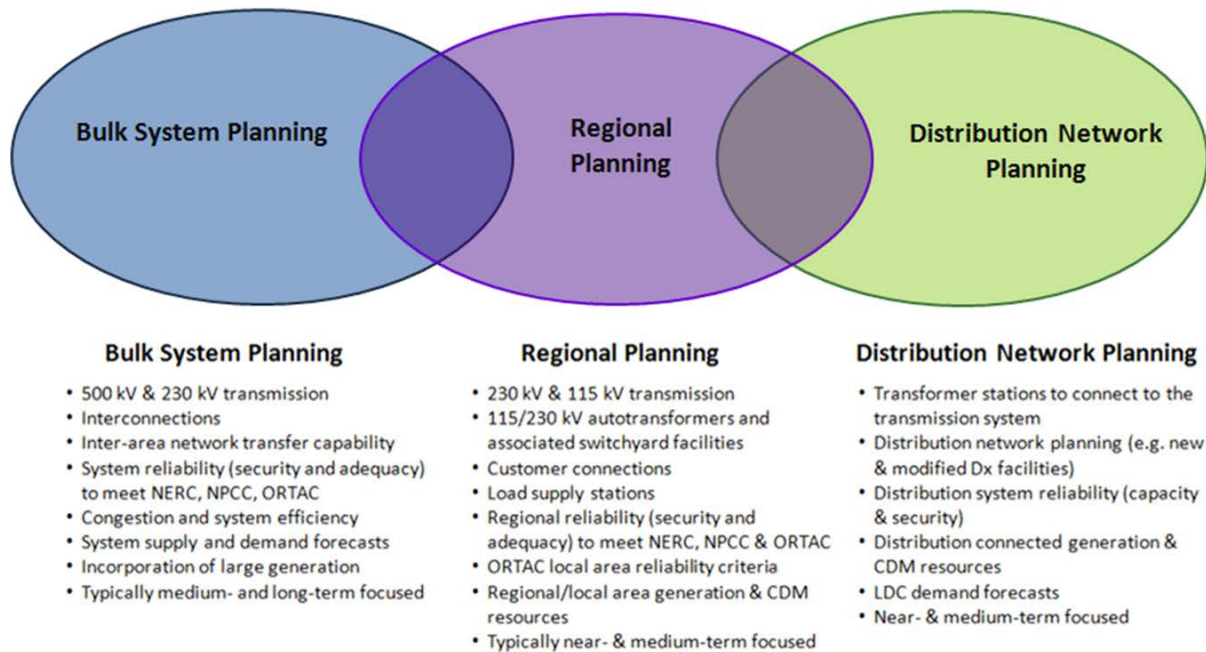

By recognizing the linkages with bulk and distribution system planning, and coordinating multiple needs identified within a region over the long term, the regional planning process provides a comprehensive assessment of a region’s electricity needs. Regional planning aligns near- and long-term solutions and puts specific investments and recommendations coming out of the plan in perspective. Furthermore, regional planning optimizes ratepayer interests by avoiding piecemeal planning and asset duplication, and allows Ontario ratepayer interests to be represented along with the interests of LDC ratepayers, and individual large customers. IRRPs evaluate the multiple options that are available to meet the needs, including conservation, generation, and “wires” solutions. Regional plans also provide greater transparency through engagement in the planning process, and by making plans available to the public.

### **3.2 The IESO's Approach to Regional Planning**

IRRP's assess electricity system needs for a region over a 20-year period. The 20-year outlook anticipates long-term trends so that near-term actions are developed within the context of a longer-term view. This enables coordination and consistency with the long-term plan, rather than simply reacting to immediate needs.

In developing an IRRP, a different approach is taken to developing the plan for the first 10 years of the plan—the near and medium term—than for the longer-term period of 10-20 years. The plan for the first 10 years is developed based on best available information on demand, conservation, and other local developments. Given the long lead time to develop electricity infrastructure, near-term electricity needs require prompt action to enable the specified solutions in a timely manner. By contrast, the long-term plan is characterized by greater forecast uncertainty and longer development lead time; as such solutions do not need to be committed to immediately. Given the potential for changing conditions and technological development, the IRRP for the long term is more directional, focusing on developing and maintaining the viability of options for the future, and continuing to monitor demand forecast scenarios.

In developing an IRRP, the IESO and the Working Group (see Figure 3-2 below) carry out a number of steps. These steps include electricity demand forecasts; technical studies to determine electricity needs and the timing of these needs; the development of potential options; and, a recommended plan including actions for the near and long term. Throughout this process, engagement is carried out with stakeholders and First Nation and Métis communities who may have an interest in the area. The steps of an IRRP are illustrated in Figure 3-2, below.

**Figure 3-2: Steps in the IRRP Process**

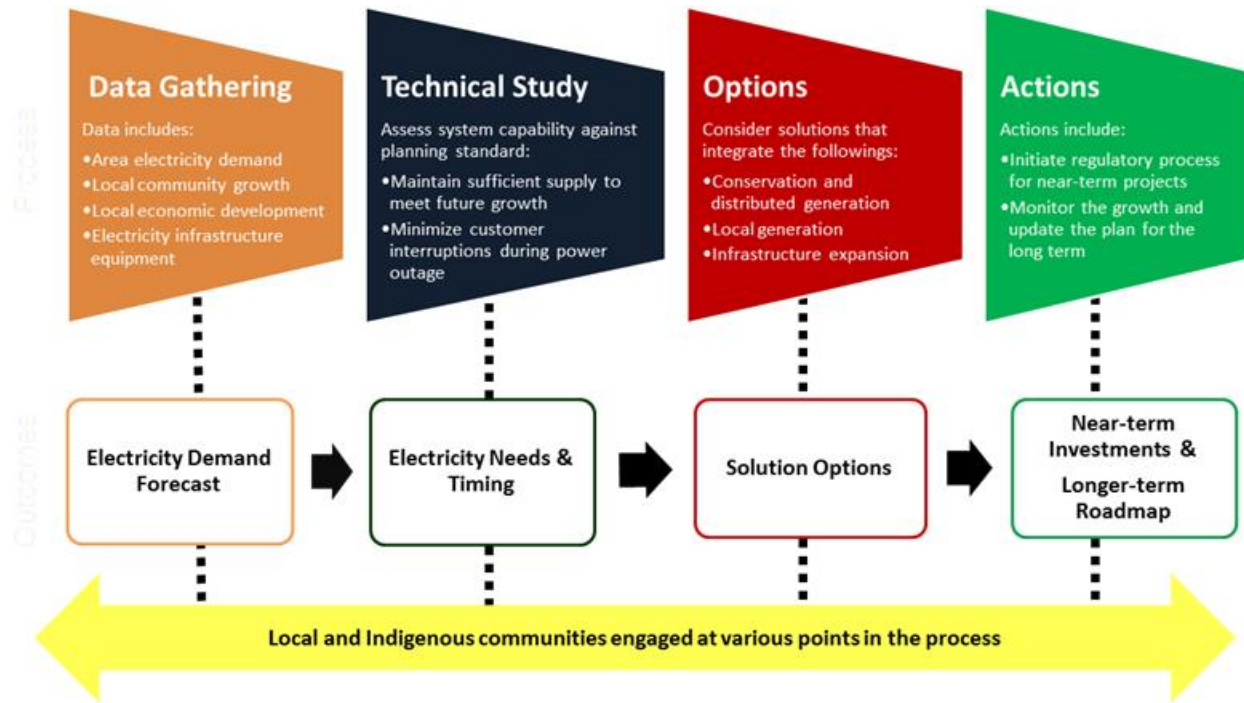

The IRRP report documents the inputs, findings and recommendations developed through the process described above, and provides recommended actions for the various entities responsible for plan implementation. Where “wires” solutions are included in the plan recommendations, the completion of the IRRP report is the trigger for the transmitter to initiate an RIP process to develop those options. Other recommendations in the IRRP may include: development of conservation, local generation, or other solutions; community engagement; or information gathering to support future iterations of the regional planning process in the region or sub-region.

### **3.3 Bronte Sub-region Working Group and IRRP Development**

The process to develop the Bronte IRRP was initiated in 2014 with the release of the Needs Screening report for the Burlington-Nanticoke Region. This product was produced by Hydro One Transmission with participation from the OPA and IESO, Brant County Power Inc.<sup>2</sup>,

<sup>2</sup> Brant County Power Inc. and Cambridge and North Dumfries Hydro Inc. became one company on January 1, 2016 when the two LDCs legally joined together as Energy+ Inc.

Brantford Power Inc., Burlington Hydro Inc., Haldimand County Hydro Inc.<sup>3</sup>, Horizon Utilities Corporation, Hydro One Distribution, Norfolk Power Distribution Inc.<sup>4</sup>, and Oakville Hydro Electricity Distribution Inc. The Needs Screening process was carried out to identify needs which may require coordinated regional planning in those sub-regions of Burlington-Nanticoke which had not already undergone a regional planning process. The subsequent Scoping Assessment Report recommended that the needs identified for the Bronte Sub-region should be further pursued through an IRRP owing to the potential for coordinated solutions.

In 2015 the Working Group was formed to develop a Terms of Reference for this IRRP, gather data, identify near- to long-term needs in the sub-region, and recommend the near and medium term actions.

---

<sup>3</sup> On March 12, 2015, the OEB approved Hydro One Network Inc.'s ("Hydro One") acquisition (EB-2014-0244) of all of the issued and outstanding shares of Haldimand County Power Inc. ("Haldimand Power"). The OEB also approved the transfer of distribution assets from Haldimand Power to Hydro One.

<sup>4</sup> On July 3, 2014, the OEB approved Hydro One's acquisition (EB-2013-0187) of all of the issued and outstanding shares of Norfolk Power Distribution Inc. ("Norfolk Power"). The OEB also approved the transfer of distribution assets from Norfolk Power to Hydro One.

## 4. Background and Study Scope

This report presents an integrated regional resource plan for the Bronte Sub-region for the 20-year period from 2015 to 2034.

To set the context for this IRRP, the scope of the planning study and the sub-region's existing electricity system are described in Section 4.1. A brief outline of the ongoing bulk system study being undertaken in the same general area, including considerations for coordination, is included in Section 4.2.

### 4.1 Study Scope

This IRRP develops and recommends options to meet supply needs of the Bronte Sub-region in the near-, medium and long term. The plan was prepared by the IESO on behalf of the Working Group. The plan includes consideration of forecast electricity demand growth, conservation and demand management ("CDM" or "conservation") in the area, transmission and distribution system capability, relevant community plans, developments on the bulk transmission system, Feed-in Tariff ("FIT") and other generation uptake through province-wide programs.

This IRRP addresses regional needs in the Bronte Sub-region, including adequacy, security and relevant asset end-of-life consideration.

The following existing transmission facilities and assumptions were included in the scope of this study:

- Stations—Bronte TS, Cumberland TS, Palermo TS, Tremaine TS, Glenorchy MTS, Oakville TS #2, Burlington DESN, and Trafalgar DESN
- Transmission circuits—B7/B8, B40/41C, T36/37B, B15/16C

The Bronte IRRP was developed by completing the following steps:

- Preparing a 20-year electricity demand forecast and establishing needs over this timeframe.
- Examining the Load Meeting Capability ("LMC") and reliability of the existing transmission system supplying the Bronte Sub-region, taking into account facility ratings and performance of transmission elements, transformers, local generation, and other facilities such as reactive power devices. Needs were established by applying ORTAC.

- Establishing feasible integrated alternatives to address needs, including a mix of CDM, generation, transmission and distribution facilities, and other electricity system initiatives.
- Evaluating options using decision-making criteria which included: technical feasibility, cost, reliability performance, flexibility, environmental and social factors.
- Developing and communicating findings, conclusions and recommendations.

**Figure 4-1: Regional Transmission Facilities**

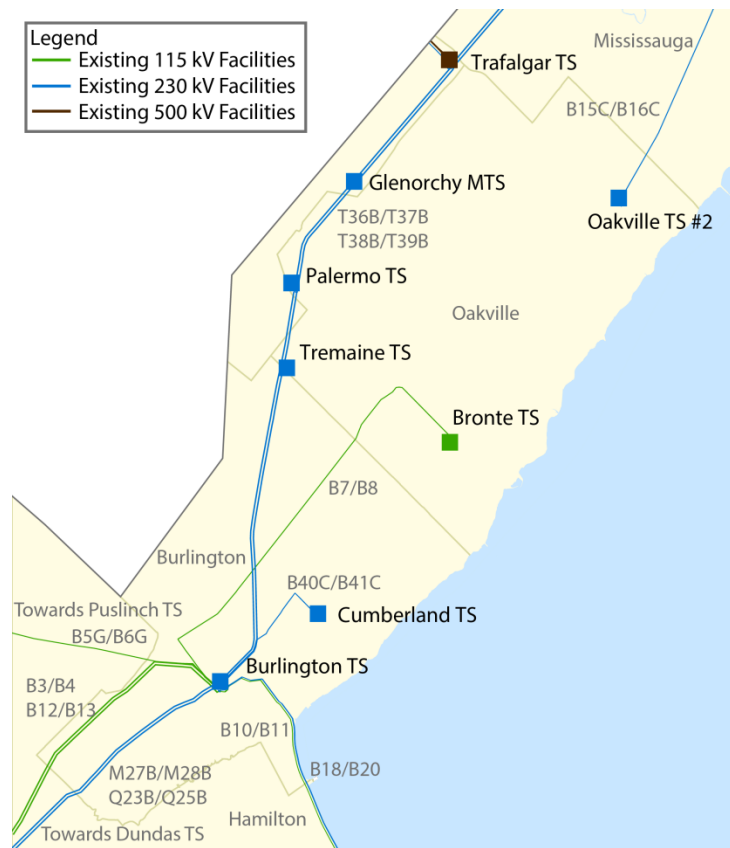

Of the step-down stations included in the Bronte Sub-region, only Bronte TS, Cumberland TS, and Burlington DESN were originally part of the Burlington-Nanticoke Region. The defined area of Bronte Sub-region, however, has been expanded outside this area to include step-down stations that serve Burlington Hydro and Oakville Hydro in the GTA West Region (Tremaine TS, Palermo TS, Glenorchy MTS, Trafalgar DESN, and Oakville TS #2). Expanding the scope of the study area to include these stations ensured that a full range of transmission and distribution alternatives was considered within the study.

Figure 4-2 shows the electrical configuration of the main stations, supply sources, and transmission assets for the Bronte Sub-region, and southern GTA West Region. Note that this diagram shows anticipated outcomes from the ongoing “GTA West Bulk System Study”, detailed in Section 4.2. This includes retermination of circuits at Milton TS, and a new supply arrangement for Halton TS and Meadowvale TS. Also included is the proposed Halton Hills Hydro Inc. (“HHH”) MTS, recommended as part of the North West GTA IRRP, and currently seeking approval through the HHH rate application.

**Figure 4-2: Bronte Sub-region Electrical Sub-systems**

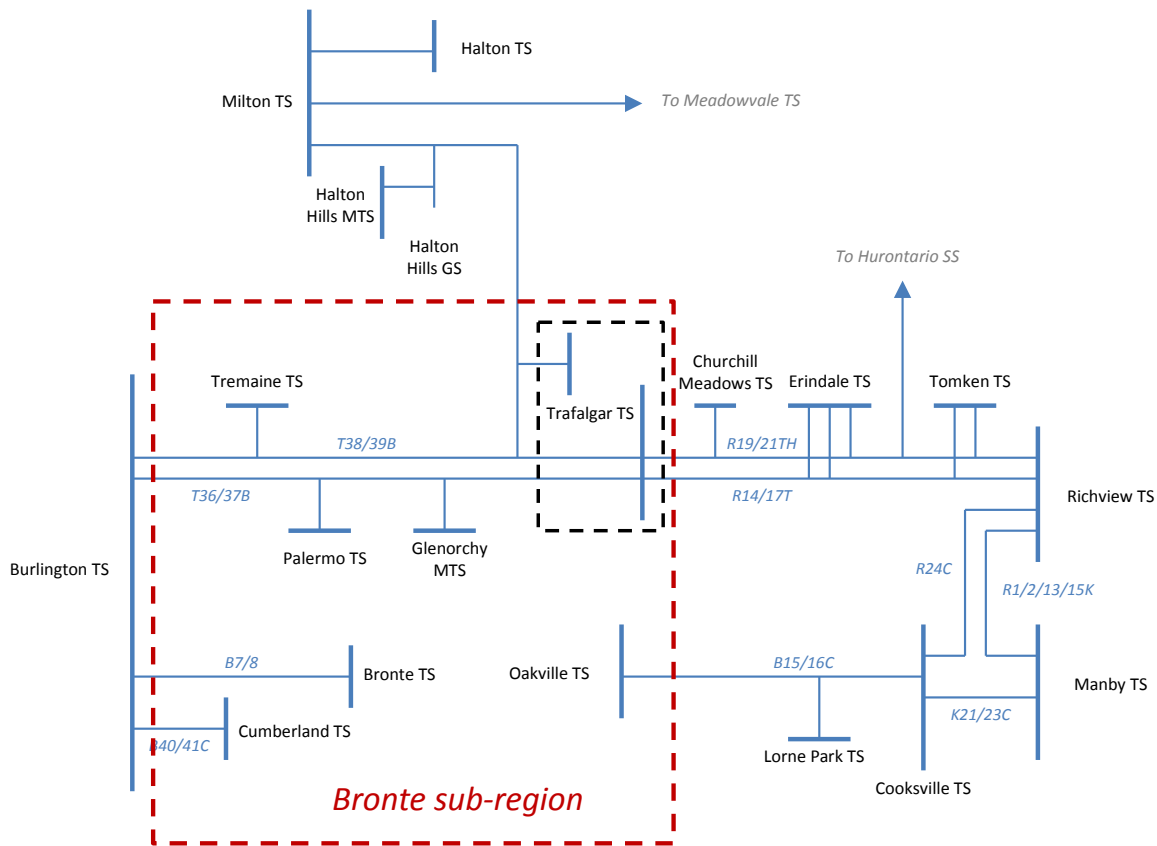

## 4.2 Bulk Transmission System Study

Due to the potential for overlap between bulk and regional planning, as described in Section 3.1, it is important for regional planning to be coordinated with bulk system planning. This is particularly important when there is ongoing bulk planning within the study area. That is because a bulk system study can integrate bulk and regional needs that may be more efficiently

solved through bulk system evaluations. Regional planning therefore needs to account for planned bulk system upgrades.

A bulk system study was initiated by the IESO for GTA West in 2014 to identify and recommend solutions to address emerging bulk transmission system needs. These needs differ from those driving the regional plan, as they are impacted by changes in the broader Ontario electricity system, rather than the local system. These needs include planned refurbishment and retirement of nuclear generation facilities, incorporating renewable generation in southwest Ontario and changes in electricity consumption patterns across the GTA.

Preliminary results indicated that upgrades to the bulk transmission system in the GTA West area are linked to the retirement of Pickering Nuclear Generation Station (“Pickering NGS”). Recommended upgrades include the installation of new autotransformers at Milton Switching Station (“SS”), incorporation of a 230 kV switchyard, and reconfiguration of the 230 kV transmission system serving the area.

In early 2016 the Ontario government and IESO announced plans for the extended operation of Pickering NGS to 2024. This updated generation assumption requires that the original bulk system study be revised. This work is currently underway.

Following the completion of the updated bulk system study and the release of the 2017 LTEP, a review will be conducted to ensure that any outcomes of the Bronte Sub-region IRRP remain valid in light of any changing assumptions.



## 5. Demand Forecast

This section outlines the forecast of electricity demand within the Bronte Sub-region. It highlights the assumptions made for peak-demand load forecasts, and the contribution of conservation and DG to reducing peak demand. The resulting net demand forecast is used in assessing the electricity needs of the area over the planning horizon.

To evaluate the adequacy of the electric system, the regional planning process involves measuring the demand observed at each station for the hour of the year when overall demand in the study area is at a maximum. This is called “coincident peak demand” and represents the moment when assets are most stressed and resources most constrained. This differs from a non-coincident peak, which is measured by summing each station’s individual peak, regardless of whether the stations’ peaks occur at different times of the area’s overall peak.

Within the Bronte Sub-region, the peak loading hour for each year typically occurs in mid-afternoon of the hottest weekday during summer, driven by the air conditioning loads of residential and commercial customers. This typically occurs on the same day as the overall provincial peak, but may occur at a different hour in the day.

Section 5.1 begins by describing the historic electricity demand trends in the sub-region from 2005 to 2014. Section 5.2 describes the demand forecast used in this study and the methodology used to develop it.

### 5.1 Historical Demand

The Burlington and Oakville Hydro coincident peak electrical demand for the Bronte Sub-region is shown in Figure 5-1. The historical actual data (in red) shows the coincident peak demand for the year.

The historical extreme weather line (in blue) shows the demand at the same hour, but it has been adjusted to reflect the expected behaviour under extreme weather conditions. Correction factors between actual and extreme conditions are produced on a zonal basis by Hydro One, the transmitter in this area.

**Figure 5-1: Historical Peak Demand in the Bronte Sub-region**

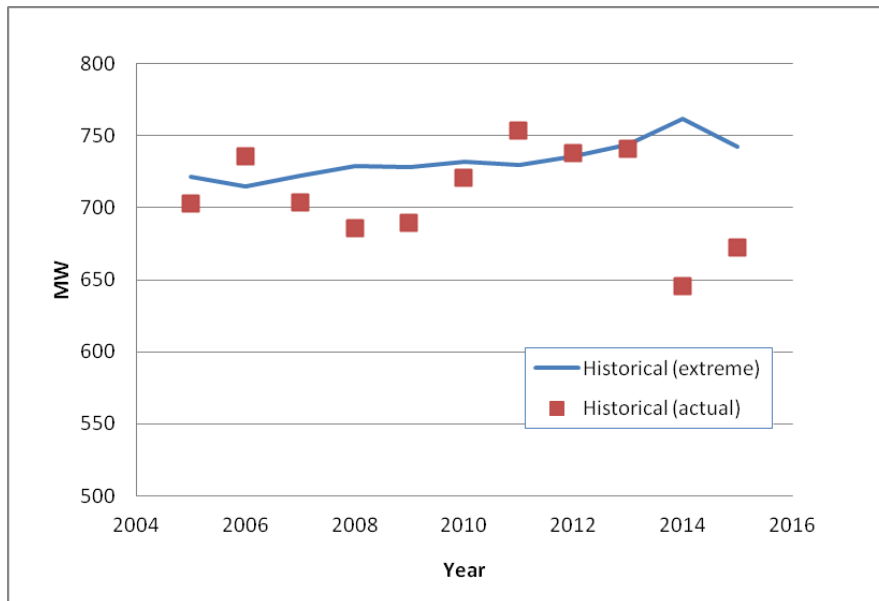

The weather corrected peak shows that demand has been generally increasing over the past decade, with a slight dip in the most recent year. However, the data for summer of 2014 and 2015 should be regarded as less reliable due to abnormally cool summer conditions. Although an extreme weather correction has been applied in all cases, these methodologies are generally not designed to make such extreme adjustments.

Historical demand, as measured at the station level, already accounts for the impact of conservation measures and other demand reducing programs in service at the time of peak. For example, verified peak demand savings from conservation programs show that 24.3 MW of peak demand was offset in 2014 across the combined Burlington Hydro and Oakville Hydro loads. In the absence of these conservation programs, growth in peak demand would have been more pronounced. The graph below shows the extreme weather corrected peak for 2010-2014<sup>5</sup>, and the equivalent peak without the reduction from verified CDM programs from 2011-2014:

<sup>5</sup> Verified conservation impacts for summer of 2015 will be available September 2016

**Figure 5-2: Historical Peak Demand in the Bronte Sub-region, Gross and Net**

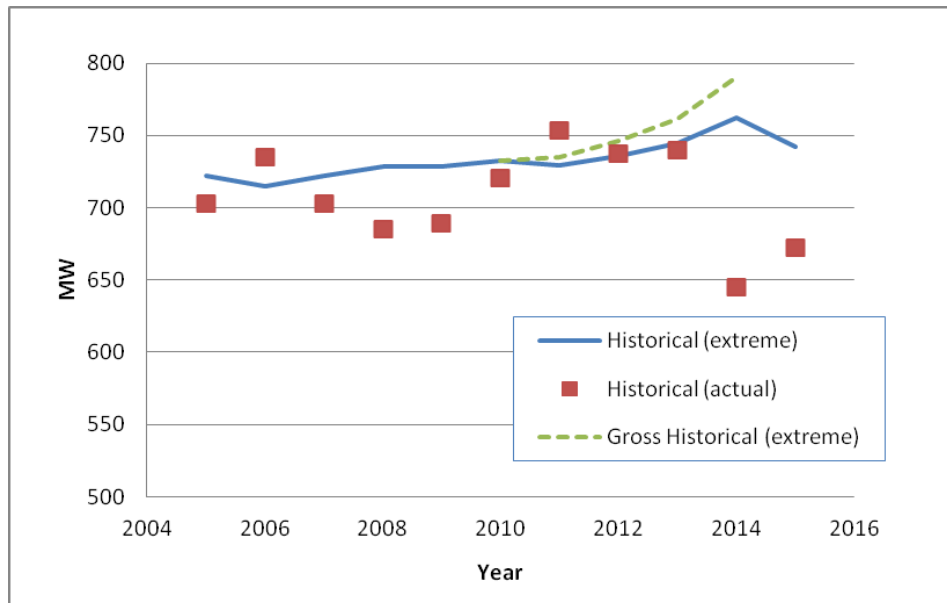

## 5.2 Demand Forecast Methodology

For the purpose of the IRRP, a 20-year planning forecast was developed to assess electricity supply and reliability needs at the regional level.

Regional electricity needs are driven by the limits of the transmission infrastructure supplying an area, which is sized to meet peak-demand requirements. Regional planning therefore typically focuses on growth in regional-coincident peak demand.

The 20-year planning forecast is divided notionally into three timeframes. The near term (0-5 years) has the highest degree of certainty; any near-term needs must typically be addressed through regional transmission or distribution solutions as there is not sufficient time to address longer-term conservation or DG solutions. The medium term (5-10 years) provides more lead time to develop and incorporate conservation and DG options. The long-term forecast covers the 10-20 year period and has the lowest degree of certainty. It is used for identifying potential longer-term needs and, as necessary, considering and developing integrated solutions (including conservation, DG, major transmission upgrades). Early identification of these needs and potential solutions makes it possible to begin engagement with the local community and all levels of government long before the need is triggered. This provides the greatest opportunity to gain input on decision making, and to ensure local planning can account for new infrastructure.

The regional peak demand forecast was developed as shown in Figure 5-3. Gross demand forecasts, assuming normal-year weather conditions, were provided by the LDCs and the transmission-connected customers in the LDC’s service territory. The LDC forecasts are based on growth projections included in regional and municipal plans, which in turn reflect the province’s Places to Grow policy. These forecasts were then modified to produce a planning forecast — i.e., they were adjusted to reflect the peak demand impacts of provincial conservation targets and DG contracted through provincial programs such as FIT and microFIT and to reflect extreme weather conditions. The planning forecast was then used to assess any growth-related electricity needs in the region.

**Figure 5-3: Development of Demand Forecast**

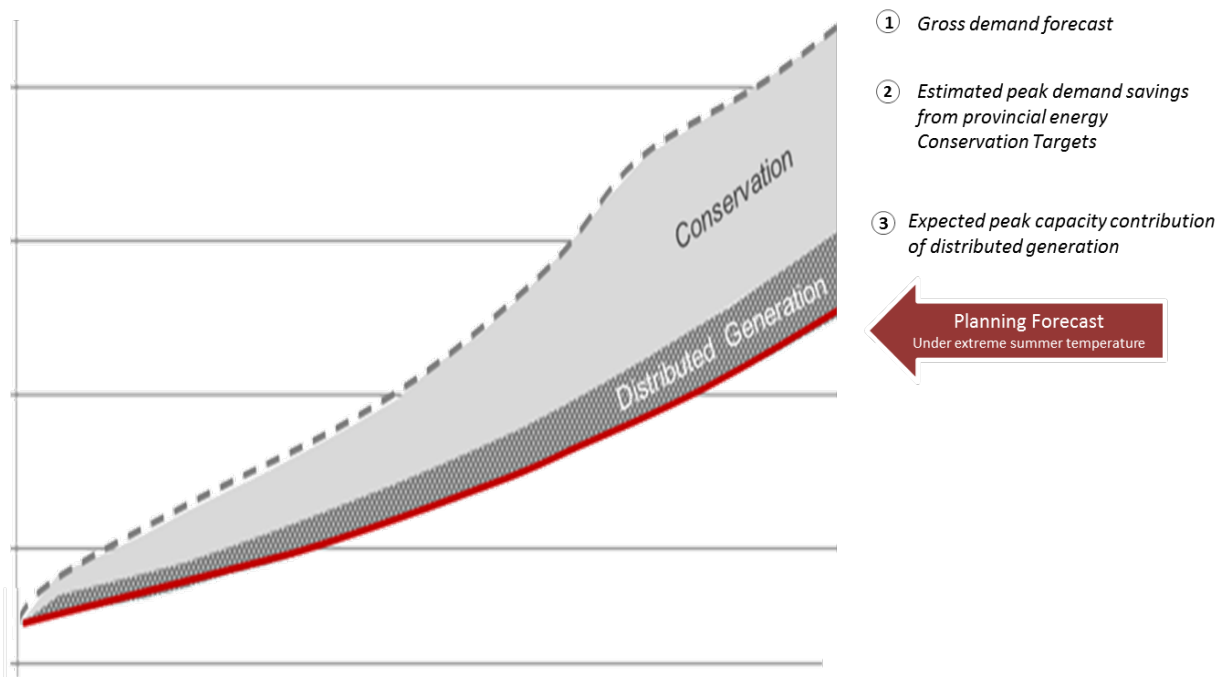

Using a planning forecast that is net of provincial conservation targets is consistent with the province’s Conservation First policy. However, it also assumes that the targets will be met and that the targets, which are energy-based, will produce corresponding local peak demand reductions. An important aspect of plan implementation will be monitoring the actual peak demand impacts of conservation programs delivered by the local LDCs and, as necessary, adapting the plan. Additional details related to the development of the demand forecast are provided in Appendix A.

### 5.3 Gross Demand Forecast

Each participating LDC in the Bronte Sub-region prepared gross demand forecasts at the transformer station level or bus level for multi-bus stations. Gross demand forecasts account for increases in demand from new or intensified development, but do not account for the impact of new conservation measures such as codes & standards or DR programs. However, LDCs are expected to account for changes in consumer demand resulting from typical efficiency improvements and response to increasing electricity prices, which is termed “natural conservation”.

Since LDCs have the most direct experience with customers and applicable local growth expectations, their information is considered the most accurate for regional planning purposes. Most LDCs cited alignment with municipal and regional official plans as a primary source for input data. Other common considerations included known connection applications and typical electrical demand intensity for similar customer types.

The graph below shows the gross demand forecast information provided by LDCs for the Bronte Sub-region, with historical data points provided for comparison.

**Figure 5-4: Bronte Sub-region Gross Forecast**

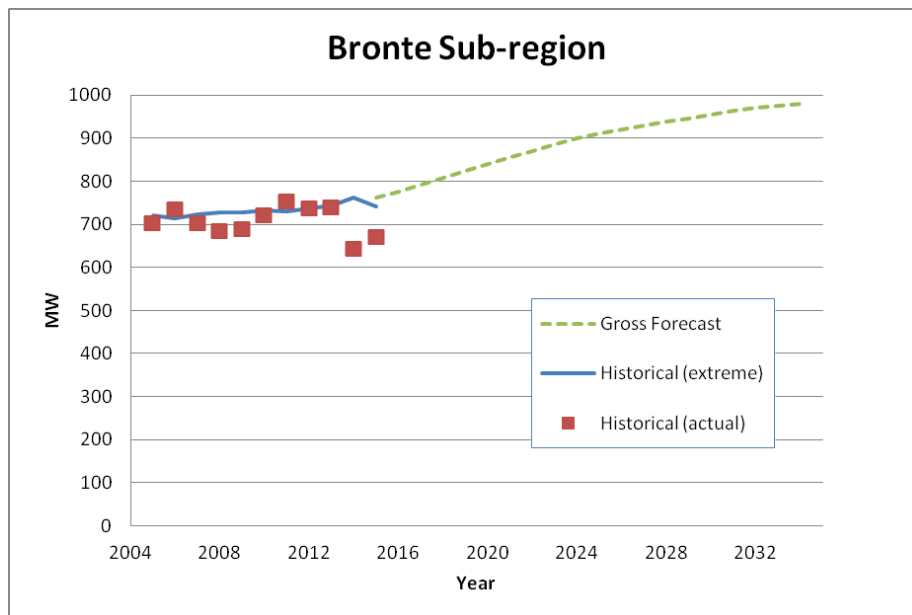

Total annual growth averages 1.3% for the study area over the 20-year planning horizon. Growth is highest in the first 10 years at an average of 1.9% per year, before reducing to an

average of 0.8% per year for the second 10 years. Although the forecast is shown for the entire study area, individual stations are forecast to experience different growth rates.

Forecasts were provided based on best available information and, as appropriate, will be updated going forward. The gross demand forecasts by station are provided in Appendix A.

## 5.4 Conservation Assumed in the Forecast

Conservation is the first resource to be considered in planning, approval and procurement processes. It plays a key role in maximizing the utilization of existing infrastructure and maintaining reliable supply by keeping demand within equipment capability. Conservation is achieved through a mix of program-related activities, rate structures, and mandated efficiencies from building codes and equipment standards. The conservation savings forecast for the Bronte Sub-region have been applied to the gross peak-demand forecast, along with DG resources (described in Section 5.5), to determine the net peak demand for the sub-region.

In December 2013 the Ministry of Energy released a revised LTEP that outlined a provincial conservation target of 30 terawatt-hours (“TWh”) of energy savings by 2032. The expected peak demand savings from meeting this target was estimated for the Bronte Sub-region. To estimate the impact of the conservation savings in the sub-region, the forecast provincial savings were divided into three main categories:

**Figure 5-5: Categories of Conservation Savings**

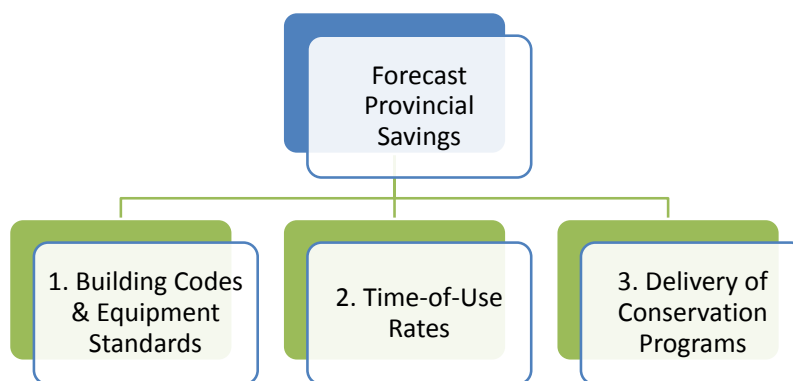

1. *Savings due to Building Codes & Equipment Standards*
2. *Savings due to Time-of-Use Rate structures*
3. *Savings due to the delivery of Conservation Programs*

The impact of estimated savings for each category was further broken down for the Bronte Sub-region by the residential, commercial and industrial customer sectors. The IESO worked together with the LDCs to establish a methodology to estimate the electrical demand impacts of the energy targets by the three customer sectors. This provides a better resolution of forecast conservation, as conservation potential estimates vary by sector due to different energy consumption characteristics and applicable measures.

For the Bronte Sub-region, LDCs were requested to provide a breakdown of their gross demand forecast, and a breakdown of electrical demand by sector for the forecast, at each TS. For TSs that an LDC could not provide gross load segmentation, the IESO and the LDC worked together using best available information and assumptions to derive sectoral gross demand. For example, LDC information found in the OEB’s Yearbook of Electricity Distributors<sup>6</sup> was used to help estimate the breakdown of demand. Once sectoral gross demand at each TS was estimated, the next step was to estimate peak demand savings for each conservation category: codes and standards, time-of-use rates, and conservation programs. The estimates for each of the three savings groups were done separately due to their unique characteristics and available data.

The table below shows the final estimated conservation reductions applied to the gross demand to create the planning forecast. Note that only the impacts from Burlington Hydro and Oakville Hydro customers are included (as opposed to total conservation within the sub-region, including from other LDCs).

**Table 5-1: Peak Demand MW Savings from 2013 LTEP Conservation Targets, Select Years**

Year	2016	2018	2020	2022	2024	2026	2028	2030	2032
Savings (MW)	9.1	19.8	36.2	45.7	57.3	70.9	83.1	94.5	100.4

Additional conservation forecast details are provided in Appendix A.

---

<sup>6</sup> OEB Yearbook of Electricity Distributors:  
<http://www.ontarioenergyboard.ca/OEB/Industry/Rules+and+Requirements/Reporting+and+Record+Keeping+Requirements/Yearbook+of+Distributors>

## 5.5 Distributed Generation Assumed in the Forecast

In addition to conservation resources, DG in the Bronte Sub-region is also forecast to offset peak demand requirements. The introduction of the *Green Energy and Green Economy Act, 2009*, and the associated development of Ontario's FIT program, has increased the significance of distributed renewable generation in Ontario. This renewable generation, while intermittent in nature, contributes to meeting the electricity demands of the province.

After applying the conservation savings to the demand forecast as described above, the forecast is further reduced by the expected peak contribution from contracted, but not yet in-service, DG in the sub-region. The effects of projects that were already in-service prior to the base year of the forecast were not included as they are already embedded in the actual demand which is the starting point for the forecast. Potential future (but un-contracted) DG uptake was not included and is instead considered as an option for meeting identified needs.

Based on the IESO contract list as of September 2015, new DG projects are expected to offset an incremental 2.68 MW of peak demand within the Bronte Sub-region by 2018. All contracts are for small scale solar projects (<500 kW). A capacity contribution of 34% has been assumed to account for expected output during peak summer conditions.

Additional details of the regional demand reductions from province-wide DG programs are provided in Appendix A.

## 5.6 Planning Forecasts

After taking into consideration the combined impacts of conservation and DG, a 20-year planning forecast was produced.

Figure 5-6 below illustrates the planning forecast, along with historic demand in the area. Note that the net forecast is for extreme weather conditions. Further details of the planning forecast scenarios are provided in Appendix A.



Figure 5-6: Bronte Sub-region Planning Forecast

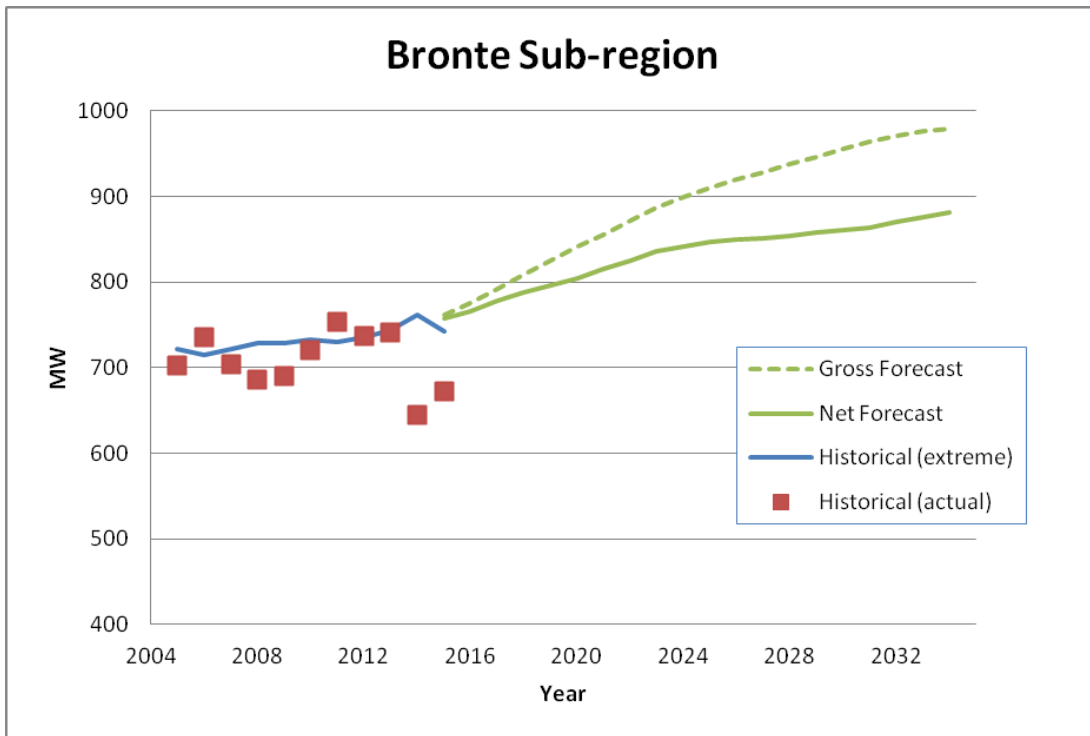

## 6. Needs

Based on the planning forecasts, system capability, and application of provincial planning criteria, the Bronte Sub-region Working Group identified electricity needs in the near, medium, and long term. This section describes the identified needs for these three time horizons in the Bronte Sub-region.

### 6.1 Needs Assessment Methodology

ORTAC<sup>7</sup>, the provincial standard for assessing the reliability of the transmission system, was applied to assess supply capacity and reliability needs. ORTAC includes criteria related to the assessment of the bulk transmission system, as well as the assessment of local or regional reliability requirements (see Appendix B for more details).

Through the application of these criteria, four broad categories of needs have been identified for the Bronte Sub-region IRRP:

- **Transformer Station Capacity** is the electricity system's ability to deliver power to the local distribution network through the regional transformer stations. This is limited by the 10-day Limited Time Rating ("LTR") of the step-down transformer stations in the local area. Transformer station capacity need is identified when the peak demand at step-down transformer stations in the local area exceeds the combined LTR ratings.
- **Supply Capacity** is the electricity system's ability to provide continuous supply to a local area. This is limited by the load meeting capability ("LMC") of the transmission lines supplying the area. The LMC is the maximum demand that can be supplied on a transmission line or group of lines as prescribed by ORTAC. LMC studies are conducted using power system simulations analysis (see Appendix B for more details). Supply capacity needs are identified when peak demand on the transmission lines exceeds the LMC.
- **Load Security and Restoration** is the electricity system's ability to keep the magnitude of electrical demand interrupted after a major prolonged transmission outage within the levels specified in ORTAC, including the time required to restore service. A major transmission outage would include a contingency on a double-circuit tower line resulting in the prolonged loss of both circuits. Load security concerns the magnitude of peak customer electrical demand which is susceptible to supply interruption in the event of a major transmission outage. Load restoration concerns the time periods within

---

<sup>7</sup> [http://www.ieso.ca/imoweb/pubs/marketadmin/imo\\_req\\_0041\\_transmissionassessmentcriteria.pdf](http://www.ieso.ca/imoweb/pubs/marketadmin/imo_req_0041_transmissionassessmentcriteria.pdf)

which the interrupted customer demand should be restored following a major prolonged transmission outage. The specific load security and restoration requirements prescribed by ORTAC are described in Appendix B.

- **Service quality** concerns factors which can impact the effective, efficient, or economic operation of the local power system, both under normal operating conditions and following contingency events. This includes maintaining voltage within specified limits, and overall reliability performance.

The needs assessment may also identify requirements related to equipment end-of-life and planned sustainment activities. Equipment reaching end-of-life and planned sustainment activities may have an impact on the needs assessment and option development.

## 6.2 Needs

Two separate needs were identified which impact the ability of Bronte TS to serve local loads:

1. **Overloads of 115 kV B7/B8 circuits.** The two 115 kV circuits supplying Bronte TS are limited by a 3 km line section which is rated at 750 A and is susceptible to overloading. This is lower than the 850 A for the remaining 14 km, which is not overloaded. As a result, load at Bronte TS must be kept below approximately 135 MW in order to respect the long-term emergency rating of the line.
2. **Post contingency voltage drop below acceptable criteria.** Bronte TS is made up of two separate buses, BY and Q. When load on BY exceeds approximately 80 MW, and total station load exceeds approximately 149 MW, the bus voltage drops more than 10% following the loss of circuit B7. Voltage drops of this magnitude are not acceptable under ORTAC. The exact loading limit for Bronte TS depends on the load balance between the two buses.

In addition to the two issues impacting Bronte TS, the following needs were also identified within the broader sub-region:

1. **Power Factor at Cumberland TS.** The IESO Market Rules require a station to be operated with a power factor of 0.9 or higher. Lower ratings indicate less efficient operation and can trigger thermal and voltage issues.
2. **Capacitor bank operation at Oakville TS #2.** Due to concerns over voltage imbalance, a station capacitor bank cannot currently be used. This limits the amount of load which can be served.
3. **Restoration needs.** Two areas within the Bronte study area have been identified as being at risk for not meeting restoration levels as defined in ORTAC.

These needs are described in greater detail in the following sections.

### **6.2.1 Overload of B7/B8**

Bronte TS is served by two 115 kV circuits (B7 and B8) which emanate from Burlington TS and end at Bronte TS. Under ORTAC, each circuit must be capable of supplying total peak load for Bronte TS, without the need to curtail (reject) load, following the sudden loss of the companion circuit.

For the B7/B8 circuits, the most limiting contingency is the loss of B7, as the Long Term Emergency (“LTE”) rating of B8 is the lower of the two, at 750 A (compared to 770 A). Further, the limiting section of B8 is 3 km in length, while the remaining 14 km has a slightly higher rating, at 850 A. Since the lowest rating must be respected, the effective LTE rating of the entire line is therefore 750 A.

The load in MW that can be accommodated by a rating of 750 A can vary depending on system conditions (including customer power factor and system voltage). In this case, it was determined to be approximately 135 MW based on prevailing conditions.

Total Bronte TS load is forecast to exceed 135 MW beginning in 2018 however this limit has already been exceeded during the 2012 and 2013 summer peaks. In each of these instances, B7 and B8 circuits were both in service, and as a result operated within their thermal limits. Had one of the lines experienced a sudden fault during these peaks, system operators would have required the immediate transfer of load away from the station, or load shedding, to keep the remaining circuit below its LTE. Actual LTE at the time of any fault would have been influenced by actual weather conditions, including temperature, sunlight, and wind.

Although the sudden loss of circuit is a relatively rare event, ORTAC requires that the system be capable of supplying all peak load in the event of this type of contingency.

### **6.2.2 Bronte TS – Post Contingency Voltage Drop**

Immediately following the loss of any one system element, ORTAC requires that voltage on the distribution side of a step-down station drop no more than 10%.

The risk of a large sudden voltage drop is greater with radially supplied loads, and increases as more load is being supplied, particularly as the thermal limit of the station transformers is approached. These conditions apply at Bronte TS, making it particularly vulnerable.

Due to the configuration of Bronte TS, the loss of the B7 circuit triggers a larger voltage drop than the loss of B8, so it is again the more limiting of the two contingencies.

Voltage drop is also impacted by the distribution of load between the two Bronte TS buses. Based on the loading profiles provided by LDCs when developing the load forecast, the 10% post contingency voltage drop constraint is expected to become limiting when total station load reaches 143 MW, which is forecast to occur in 2021. This assumes BY bus loading of 83 MW, and Q bus loading of 60 MW.

However, if load is optimally distributed between the two buses, up to 149 MW of load could be served before reaching the 10% post contingency voltage drop, which is forecast to occur in 2033. This assumes BY bus loading of 79 MW, and Q bus loading of 70 MW.

Additional information on this need is provided in Appendix B.

### **6.2.3 Cumberland TS – Power Factor**

An investigation was undertaken over the course of the IRRP to examine reported power factor issues at the Cumberland TS.

Based on historical records of hourly power factor data, it was determined that Cumberland TS has been frequently operating below a 0.9 power factor over the past several years. Lower power factors represent a less efficient operation of the system (by lowering the amount of active power which can be provided to customers), and can have a negative impact on local service quality. In addition, the high voltage side of a transformer must maintain a power factor of 0.9 or higher (leading or lagging) as per ORTAC.

This particular issue can be addressed by “wires” infrastructure. Hydro One and Burlington Hydro will further assess this issue and develop a mitigation plan as part of the RIP.

### **6.2.4 Oakville TS #2 – Capacitor Bank Operation**

Oakville TS #2 station capacity is dependent on the operation of the capacitor bank located at one of the two buses. If not in operation, station loading is limited to around 138 MW, in order to respect 10% post contingency voltage drop. If the capacitor bank is in operation, up to 152 MW can be accommodated at the station. Although use of the capacitor bank improves load meeting capability as well as providing additional local benefits (power factor control), it has not been used over the past few years. Hydro One indicated that the reason it has not been

operated is that energizing the bank could create a voltage imbalance of over 7% between the two buses, which may lead to false operation of protections at the station. Protections quickly disconnect faults which could endanger safety or cause damage to equipment if it remains energized. False operation of protections cause unnecessary interruption to customers and should be avoided.

Adding a second capacitor bank (such that both buses have equal voltage support) would eliminate this constraint and effectively increase Oakville TS #2 loading capacity from 138 MW to 169 MW. This would cost approximate \$3 million.

It should be noted, however, that, even with this increased station capacity, Oakville TS #2 is not a suitable location for providing supply to Bronte TS at this time (see Section 7.1.3.2), and as a result it is not anticipated that additional capacity will be required over the study period at this station. In the event that electrical demand at Oakville TS #2 exceeds 138 MW (which may occur if a large customer connects), it is recommended that this constraint be reviewed. This need will not be considered further in the scope of this IRRP.

### **6.2.5 Restoration Needs**

Restoration needs refer to the ability of the system to restore sufficient amount of load within required periods of time following the prolonged loss of a major supply source from the transmission system.

Several areas within the Bronte Sub-region have been identified as being at risk for not meeting restoration levels as defined in ORTAC. ORTAC indicates that, for the loss of two elements, any load in excess of 250 MW should be restored within 30-minutes and any load in excess of 150 MW should be restored within 4 hours. The assessment also considers restoration of all loads within eight hours. These restoration levels are summarized in Figure 6-1, below.

**Figure 6-1: ORTAC Load Restoration Criteria**

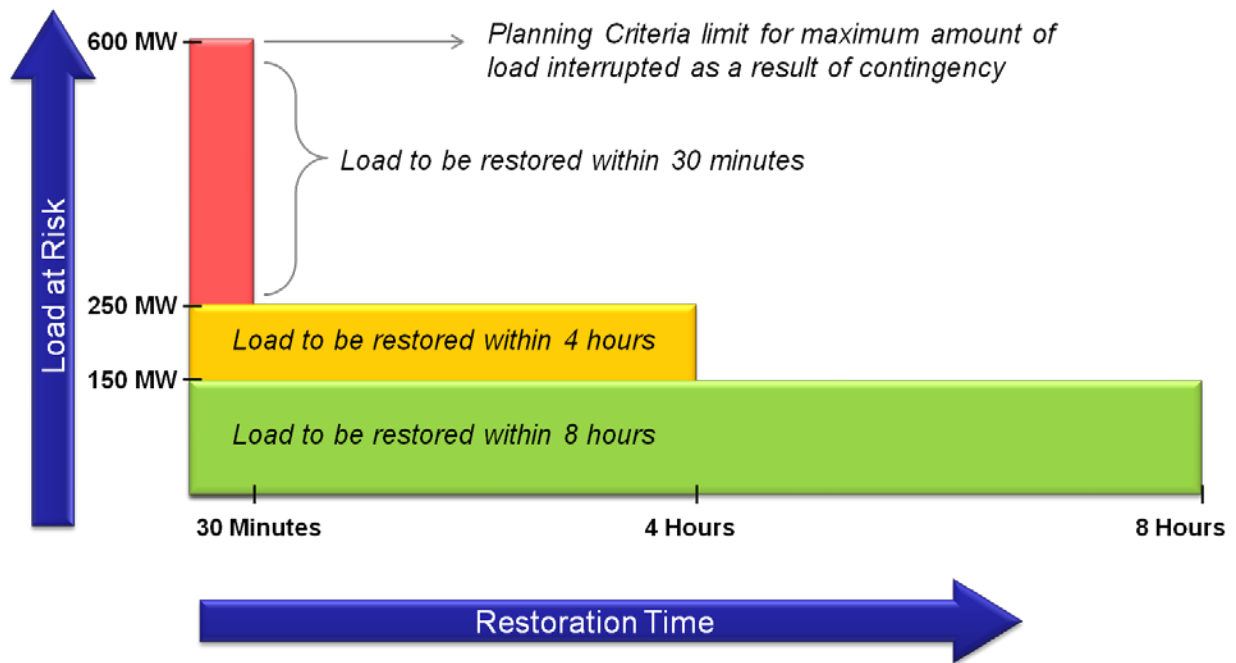

Given that the sudden loss of two transmission elements is a relatively rare event, ORTAC allows for some discretion in applying this criteria: Where a restoration need is identified, “transmission customers and transmitters can consider each case separately taking into account the probability of the contingency, frequency of occurrence, length of repair time, the extent of hardship caused and cost”.<sup>8</sup>

Some previously identified restoration needs affecting stations in this sub-region are being investigated through the West GTA Bulk System Study (more details provided in Section 4.2), particularly those related to the T38/39B circuits. It is expected that the gap in meeting restoration criteria associated with T38/39B will no longer occur following the bulk system changes planned as part of the West GTA Bulk System Study. This bulk plan includes implementing 230 kV to 500 kV transformers and a 230 kV switchyard at the existing Milton SS, and reconfiguration/retermination of transmission circuits in the area. This will remove Halton TS (including any future station expansion) and Meadowvale TS from T38/39B, lowering

<sup>8</sup> ORTAC Section 7.4 Application of Restoration Criteria -

[http://www.ieso.ca/documents/marketAdmin/IMO\\_REQ\\_0041\\_TransmissionAssessmentCriteria.pdf](http://www.ieso.ca/documents/marketAdmin/IMO_REQ_0041_TransmissionAssessmentCriteria.pdf)

the amount of load at risk of interruption. Stations which will continue to be served by T38/39B are Tremaine TS, Trafalgar DESN, and the future HHH MTS. These measures will reduce the amount of load at risk of interruption by 2034 from 646 MW to 241 MW (already meeting acceptable 30 minute restoration criteria). Combined with the present day 4 hour restoration capability of 99 MW for these stations, this means that these restoration needs will be met following the expected bulk system upgrade in GTA West.

**Figure 6-2: Restoration Pocket for T38/39B**

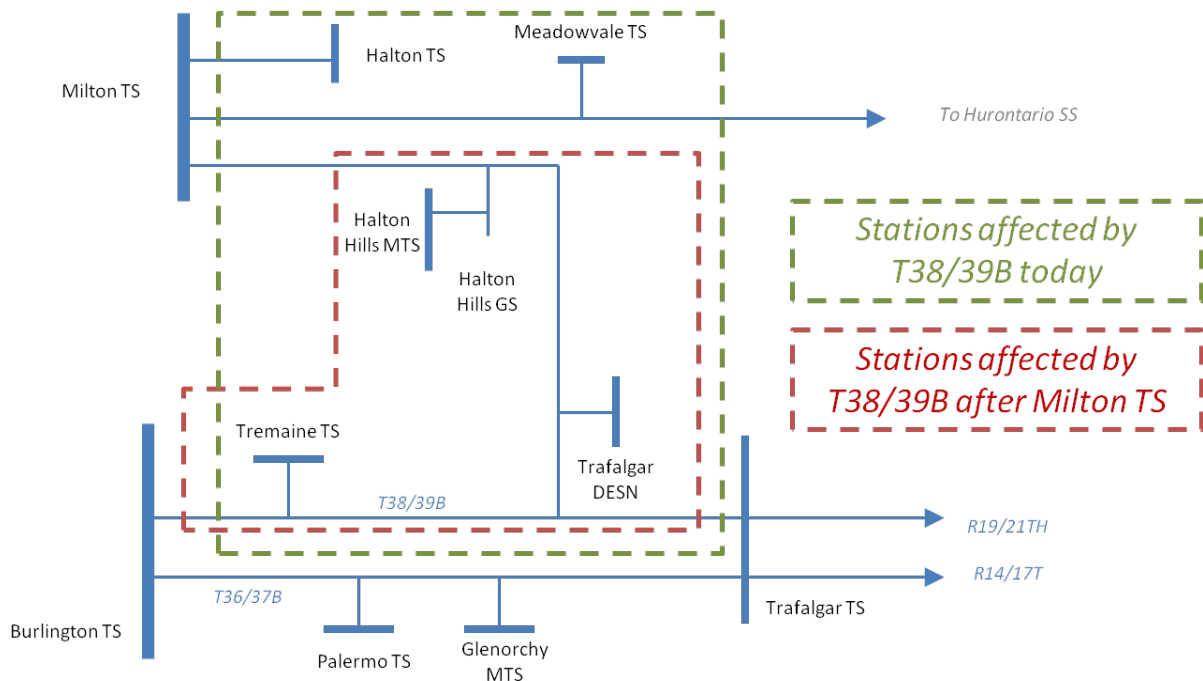

Also being considered from a restoration perspective are Palermo TS and Glenorchy MTS. As shown in Figure 6-2, above, both are at risk of supply interruption following the loss of the T36/37B circuits. However, the current forecast shows the coincident load of these stations only reaching 192 MW over the next 20 years, with 61 MW capable of being restored within of 30 minute and 116 MW capable of being restored within 4 hours through distribution transfers. This means that these stations are currently meeting restoration guidelines and do not require further analysis.

The remaining area of the Bronte Sub-region which is at risk of failing to meet restoration guidelines is the southwest GTA radial pocket. Following the simultaneous loss of both B15C and B16C circuits, supply is interrupted to Oakville TS #2 and Lorne Park TS, in addition to local direct connect industrial loads (not shown in Figure 6-3, below).



**Figure 6-3: Restoration Pocket for Southwest GTA, West of Cooksville**

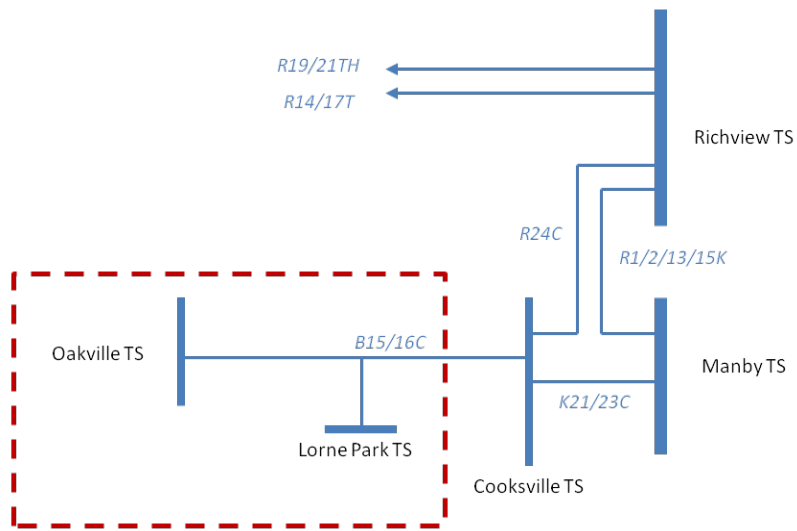

*Southwest GTA radial pocket*

The net forecast prepared for this IRRP shows that demand is expected to be relatively flat over the next 20 years, as new demand is largely offset by new conservation initiatives. In order to fully meet criteria guidelines, all load in excess of 250 MW must be restored within 30 minutes, and all load in excess of 150 MW within 4 hours, following the sudden loss of the B15/16C circuits. Given the proximity of emergency crew and equipment, all loads should be able to be restored within 8 hours through conventional transmission supply.

Table 6-1 below shows the total peak load at risk of interruption for select years, and the 30 minute and 4 hour restoration capability which would be required to meet this criteria:

**Table 6-1: Peak Load and Restoration Requirements for West of Cookville Pocket**

	2016	2018	2020	2022	2024	2026	2028	2030	2032	2034
Forecast Peak Demand	257.6	261.9	262.3	266.5	270.3	273.9	276.5	280.0	284.3	292.8
Targeted 30 Minute Restoration	7.6	11.9	12.3	16.5	20.3	23.9	26.5	30.0	34.3	42.8
30 Minute Shortfall	0	0	0	0	0	0	0	0	0	0
Targeted 4 Hour Restoration	107.6	111.9	112.3	116.5	120.3	123.9	126.5	130.0	134.3	142.8
4 Hour Shortfall	0	2.2	2.6	6.8	10.6	14.2	16.8	20.3	24.6	33.1

Based on discussions with area LDCs, up to 46 MW can be restored through distribution transfers within 30 minutes under the current supply arrangement and 110 MW within 4 hours.<sup>9</sup> The West of Cooksville pocket is expected to be able to meet the 30 minute restoration criteria over the entire study period. This leaves a 4 hour restoration shortfall beginning in year 2018, and extending throughout the rest of the study period, up to a maximum of 33 MW by 2034.

Although the magnitude of the 4 hour restoration need is small, the vulnerability to loss of supply for customers in the West of Cooksville area was highlighted during the July 8, 2013 summer rain storm. This section of line was interrupted for several hours due to outages at Richview TS and Manby TS. The likelihood of a similar outage occurring in the future is low, as preventative measures have been implemented, based on root cause analysis. However, Enersource Hydro Mississauga Inc. (“Enersource”) and Oakville Hydro have indicated that there are ongoing concerns about this reliability risk. It should be noted the bulk plan for the area is considering options which may address this situation.

### **6.3 Needs Summary**

The majority of needs in the Bronte Sub-region concern various loading limits on Bronte TS. Figure 6-4, below, shows the operable area for Bronte TS, with consideration for the B7/B8 thermal limits, 10% voltage drop criteria, and LTR of the transformers following the loss of B7 (most constraining scenario).

---

<sup>9</sup> Burlington to Nanticoke Scoping Assessment Report, [http://www.ieso.ca/Documents/Regional-Planning/Burlington\\_to\\_Nanticoke/Scoping%20Assessment%20Outcome%20Report.pdf](http://www.ieso.ca/Documents/Regional-Planning/Burlington_to_Nanticoke/Scoping%20Assessment%20Outcome%20Report.pdf)

**Figure 6-4: Loading Limits on Bronte TS, Multiple Constraints, for Loss of B7**

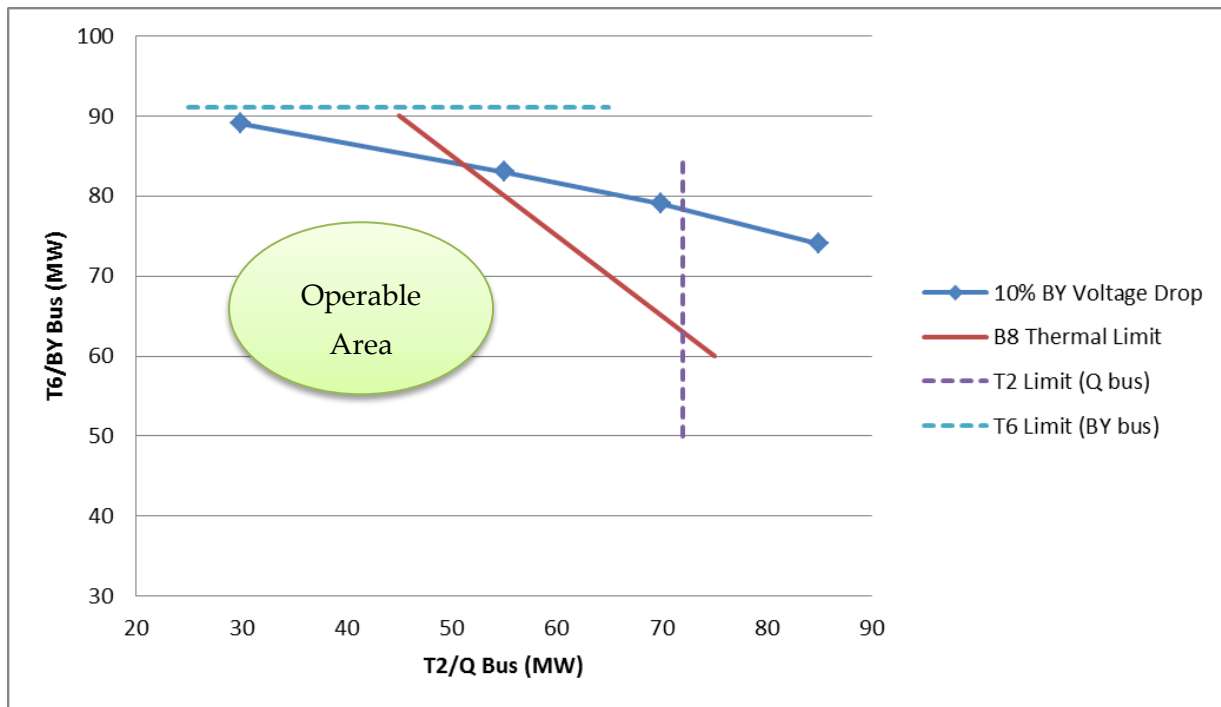

The maximum load that can be carried by Bronte TS is 135 MW in order to respect thermal limits of the B8 circuit (as shown by the legend line in red). Since this limit is not sensitive to the distribution of load between buses, any point along the limit corresponds to the same 135 MW total.

If this limit were neglected, the next highest possible load which could be carried by Bronte TS is 149 MW, which coincides with the intersection between the 10% voltage drop limit and the T2 loading limit (line in blue and broken line in purple, respectively). Note that this limit is sensitive to loading between buses, which means the maximum occurs when load on the Q bus is approximately 70 MW, and load on the BY bus is 79 MW.

In addition to Bronte TS, Cumberland TS is also currently experiencing service quality needs related to the low power factor at the high voltage bus. This need will be addressed directly between the transmitter and distributor, and will not be studied further as a part of this IRRP.

An operational issue has also been identified at Oakville TS #2, which is preventing the use of the capacitor bank, and hence limiting the loading capability of the station. However, since Oakville TS #2 is currently not forecast to exceed the reduced loading limit, this need will not be studied further as part of this IRRP.

Finally, two restoration needs currently exist in the Bronte Sub-region: T38/39B, and the West of Cooksville radial pocket. The former need is expected to be addressed through the implementation following the GTA West Bulk System Study, and as a result will not be studied further as a part of this IRRP.

The table below provides a brief summary of needs which will be considered during the development of options for the plan.

**Table 6-2: Summary of Needs in Bronte Sub-region**

<b>Area</b>	<b>Need</b>	<b>Description</b>	<b>Need Date</b>
Bronte TS	Thermal limit of B7/B8	Flows on B8 circuit exceeds Long Term Emergency Rating following loss of B7 when load is in excess of 135 MW	2018
Bronte TS	Post contingency 10% voltage drop	Voltage at Bronte TS may drop by more than 10% following loss of B7 when load is in excess of 143 MW (or 149 MW of loads can be redistributed between buses)	2021
West of Cooksville	Restoration	Restoration shortfall for the 4 hour timeline defined by ORTAC	2018

## **7. Near- and Medium-Term Plan**

This section describes the alternatives considered in developing the near- and medium-term plan for the Bronte Sub-region, provides details of and rationale for the recommended plan, and outlines an implementation plan.

### **7.1 Alternatives for Meeting Near- and Medium-Term Needs**

In developing the near- and medium-term plan, the Working Group considered a range of integrated options. The Working Group further considered technical feasibility, cost and consistency with long-term needs and options in the Bronte Sub-region when evaluating alternatives. Solutions that maximize the use of existing infrastructure were given priority, where they were otherwise determined to be cost effective.

The following sections detail the alternatives considered and address their performance in the context of the criteria described above. The alternatives are grouped according to three major solution categories: (1) conservation, (2) local generation and (3) transmission and distribution.

#### **7.1.1 Conservation**

Conservation was considered as part of the planning forecast, which includes the local peak-demand effects of the provincial conservation targets (see Section 5.4). Across the planning area, the LTEP energy reduction targets account for approximately 57 MW, or 41% of the forecast demand growth during the first 10 years of the study. Achieving the estimated peak demand reductions of the provincial conservation targets significantly reduces the extent of the Bronte TS thermal and voltage drop needs. This results in only a 15 MW capacity gap, which makes a distribution solution viable. It also effectively offsets new demand growth at this station from 2023-2030. As a result, a solution developed to address near-term needs would be sufficient for the area until roughly 2030.

In Figure 7-1, below, Bronte TS load is shown under both the gross and net forecasts (accounting for expected conservation and contracted DG). The thermal limit of B7/B8 is also shown, as it is the more constraining of the two needs identified at Bronte TS.

**Figure 7-1: Effect of Conservation Targets on Bronte TS Peak Load**

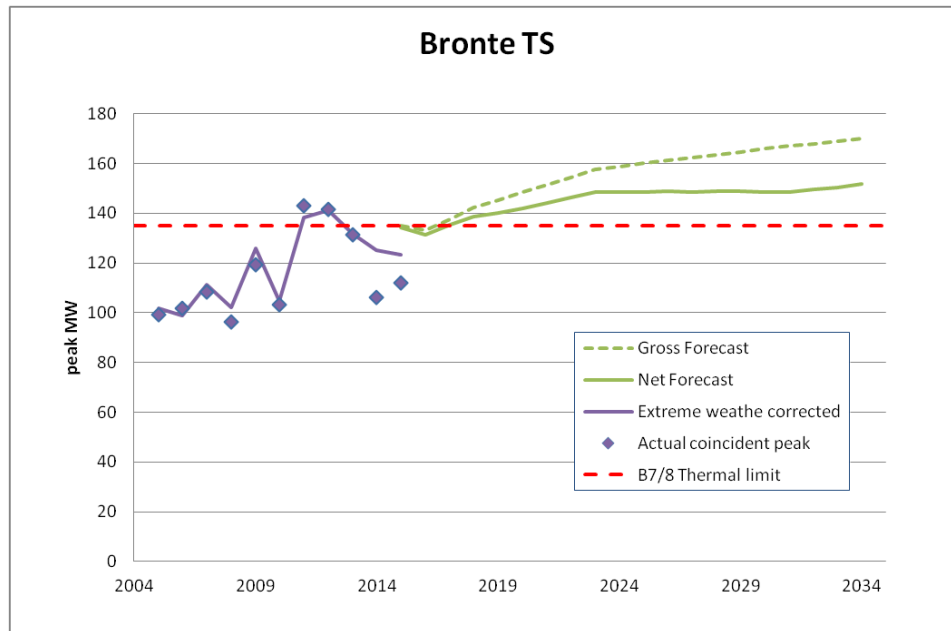

Note that the majority of conservation targets are provided in terms of energy offsets (measured over an entire year), while transmission needs are triggered based on peak demand (single highest observation in a year). As a result, in order to reduce, defer, or otherwise address needs, conservation programs must have an impact during the hour of peak demand. In the case of the Bronte Sub-region, this typically means late afternoon on the hottest weekdays of summer.

The net forecast is an estimate of how meeting the mostly energy based targets translates into peak demand reductions. There is, however, uncertainty in meeting energy conservation targets and determining how meeting those targets will translate into peak demand savings. As such, there is a wide range of potential demand impacts which could be experienced (both higher and lower than forecast), even while still achieving full conservation targets. Therefore, LDCs are encouraged to focus their Conservation First Framework (“CFF”) funding (Oakville Hydro - \$24,575,982 and Burlington Hydro - \$25,825,521) towards measures and programs that can also reduce peak and overall demand—particularly in areas where needs have been identified through regional planning—when they are working towards achieving their CFF energy savings targets.

As part of the implementation of this plan, the Working Group will review actual peak demand, including the impact of conservation, on an annual basis. The IESO is willing to consider

requests from LDCs for support with the development of a localized achievable potential study to determine the specific conservation savings potential associated with Bronte TS. The study could be used to help design conservation/DSM programs that deliver optimal customer and system benefits. If net demand trends lower at Bronte TS than expected, need dates may be deferred. On the other hand, if growth trends higher, and cannot be offset through conservation or other peak reducing activities (such as DG), additional measures may be required to address needs.

The other major need identified in the Bronte Sub-region is the restoration need following a loss of transmission supply in the West of Cooksville radial pocket. Restoration is required following a loss of supply. Power must be restored through an alternate electrical supply path, or when the original fault is cleared. Conservation does not have a bearing on these factors, and as a result is not a suitable option for addressing these types of needs.

### **7.1.2 Local Generation**

Large, transmission-connected generation and small-scale distribution-connected DG options were ruled out as viable alternatives for meeting near-term needs in the Bronte Sub-region. The sections below explain why.

#### **7.1.2.1 Generation-based Solution to Address Bronte TS Needs**

Two sets of needs are associated with Bronte TS: overloads on the B7/B8 supply circuits, and post contingency voltage drop at the station itself.

Based on the planning forecast, a transmission connected generator of approximately 20 MW would be suitable for addressing the circuit overload needs expected to emerge in 2018, but would not impact the voltage drop needs expected to begin in 2021. Although this could address some of the near-term Bronte TS needs, it was still not considered an appropriate solution for several reasons. First, it is not technically feasible to approve and construct this type of facility within the short lead time required to meet near-term needs. Second, it would be difficult and possibly infeasible to find a suitable location to host this type of facility in close proximity to Bronte TS, which is located within a highly developed area of southwest Oakville. Third, local generation would add to the overall generation capacity for the province and therefore the generation capacity situation at the provincial level must be considered. Currently, the province has a surplus of generation capacity, and no new capacity is forecast to be needed until the mid-2020s at the earliest.

Instead of a single large transmission connected generation facility, 20 MW worth of DG projects could address both the B7/B8 overload and Bronte TS voltage drop needs into the long term. However, DG projects were also determined to be technically, logistically and economically infeasible for addressing these needs because the DG facilities would need to be optimally dispersed across a number of distribution feeders. Generation would, in effect, have to fully offset any incremental demand, and be matched precisely where local demand requires. Developing and implementing such a complex solution within the time period of the need in this densely developed area was determined to be impractical.

While DG projects are not suitable for addressing near-term needs, they offer good potential for managing ongoing load growth, and thereby deferring longer-term needs. New development in the Town of Oakville offers potential to identify opportunities for large steam host customers to integrate combined heat and power (“CHP”) projects at the earliest stage of community design to meet demand and heat needs. Typically large commercial or institutional customers have suitable profiles to accommodate this type of facility. The Town of Oakville has identified goal 2.1.1 in their Environmental Strategic Plan to “Work with Oakville Hydro and other community partners to expand, access and promote alternative green energy resources (geothermal, solar, combined heat and power, etc.)”.<sup>10</sup> Additionally, the City of Burlington has proposed a target of 12.5 MW of peak electrical demand to be met through local sustainable generation by 2031.<sup>11</sup> Locating distributed energy resources in the Bronte TS service territory could provide value in deferring the need for additional investments.

Based on the planning forecast, long-term growth within the Bronte TS area is expected to average less than 1 MW per year. Assuming the recommended option (described in greater detail in Section 7.2) is adopted, new needs may begin to emerge after 2030. Acquiring approximately 10 MW of DG capacity, with the ability to dispatch during local peak demand, would thereby defer potential long-term needs for over a decade.

Potential for incremental DG to address long-term needs will be reviewed as part of future regional planning cycles, while actual uptake will be monitored on a yearly basis.

---

<sup>10</sup> Oakville Environmental Strategic Plan, 2011 Update, [http://www.oakville.ca/assets/general%20-%20environment/2011\\_ESP\\_FINAL.pdf](http://www.oakville.ca/assets/general%20-%20environment/2011_ESP_FINAL.pdf)

<sup>11</sup> Burlington Community Energy Plan, [https://www.burlington.ca/en/live-and-play/resources/Environment/Burlington\\_Community\\_Energy\\_Plan.pdf](https://www.burlington.ca/en/live-and-play/resources/Environment/Burlington_Community_Energy_Plan.pdf)



### **7.1.2.2 Generation-based Solution to Address Restoration Needs**

Generation was ruled out as a possible option to address restoration needs in the West of Cooksville radial pocket. Large generation is not a suitable option for addressing restoration needs, as it would require the facility to have blackstart and islanded operation capabilities, a costly generation and system design feature. Additionally, finding a suitable location for major generation infrastructure could be challenging given that the West of Cooksville area is largely built up with significant residential zoning.

Smaller scale DG was determined to be impractical from a technical and economic perspective, given the scale and number of facilities that would be required within the sub-region. In order to provide restoration, each of these facilities would also have to be able to supply their local loads in islanded mode. Some high value loads (such as pumping and water purification facilities) are typically developed with on-site gas or diesel generation to ensure they can continue to operate during a power supply outage. While there is benefit to building this type of supply redundancy to ensure restoration capability for some loads, it is impractical on a large scale to address local restoration needs.

### **7.1.3 Transmission and Distribution**

A number of transmission and distribution, or “wires,” solutions were considered by the Working Group to meet the near-term needs. “Wires” infrastructure solutions can refer to new or upgraded transmission or distribution system assets, including lines, stations, or related equipment. These solutions are often characterized by high upfront capital costs, but have high reliability over the lifetime of the asset.

If net growth at Bronte TS cannot be fully offset through conservation, DR, or local generation initiatives, constraints on the transmission system will have to be addressed through an electricity infrastructure based solution. Even under the full achievement of conservation targets, peak demand is forecast to exceed the existing transmission system capacity by 15 MW over the next 15 years. There are potential transmission and distribution solutions to address the Bronte TS need; these are described in greater detail in Sections 7.1.3.1 and 7.1.3.2.

Likewise, an electricity infrastructure based solution could address the restoration need for the West of Cooksville radial pocket. However, given the high costs associated with electricity infrastructure solutions, low exposure to risk represented by this event, and low likelihood of

occurrence, any measure would have to be assessed to ensure it is economic before it is recommended. This is further discussed and investigated in Section 7.1.3.3.

#### **7.1.3.1 Transmission-based Solution to Address Bronte TS Need**

The two 115 kV circuits supplying Bronte TS are limited by a 3 km section which is rated at 750 A for circuit B8, and 770 A for circuit B7. These are lower ratings than the remaining 14 km of the lines (850 A for B8, and 880 A for B7). As a result, load at Bronte TS must be kept below approximately 135 MW in order to respect the 750 A minimum LTE rating of the line. If the limiting 3 km line section was upgraded, the new thermal limit of the remaining section would be approximately 150 MW (corresponding to 850 A). Assuming full achievement of CDM targets, this measure would successfully defer the thermal need until 2033 (assuming load distributed optimally between buses according to: maximum 79 MW on BY bus, 70 MW on Q bus). At this loading level, needs associated with post contingency voltage drop would also become limiting, and no incremental load could be served at Bronte TS. This transmission upgrade would therefore enable the full usage of the step-down transformer facilities.

B7/B8 Palermo Junction to Bronte TS (3 km) is the limiting line section. Upgrading will require complete rebuild of this line section using new steel poles and 585 kcmil 26/7 Aluminum Conductor, Steel Reinforced (“ACSR”) conductor. Hydro One has indicated that budgetary estimate for rebuilding this 3 km line section is approximately \$9.7 million.

The estimated time required for upgrading Palermo Junction to Bronte TS line section is about three years which includes the OEB leave to construct application (Section 92), and environmental approvals.

#### **7.1.3.2 Distribution-based Solution to Address Bronte TS Need**

As an alternative to upgrading the limiting section of B7/B8, needs associated with Bronte TS could be addressed by keeping the total station load below 135 MW. Assuming full achievement of conservation targets, this would require approximately 15 MW of additional capacity relief to defer the need past 2030. There are two approaches to achieving this relief. One approach involves making a single feeder transfer (approximately 15 MW of load) from Bronte TS to a neighboring station to allow the 15 MW of growth to be supplied from Bronte TS. Another approach proposed by Oakville Hydro involves incrementally transferring the 15 MW away from the Bronte TS service territory to neighbouring transformer stations. These incremental load transfers would coincide with the incorporation of new electrical demand in

the remaining sections of the Bronte service area. This would result in a gradual shifting of the 15 MW to other stations over the study period while Bronte load remains fixed.

The feeder transfer would require a onetime investment in the distribution system to expand the service territory of another station into an area which is currently served by Bronte TS. The incremental load transfers would occur over time and coincide with load growth in the section of the Oakville Hydro franchise territory served by Bronte TS.

There are four stations within the general vicinity of Bronte TS which are forecast to have remaining station capacity over the 20-year planning horizon. These stations were reviewed to determine suitability for a single large or series of small continuous load transfers:

1. **Glenorchy MTS** is located approximately 14 km north and east of Bronte TS, and primarily serves Oakville Hydro load, with some embedded demand. Under the current planning forecast, over 40 MW of capacity will be available at this station over the next 20 years. Oakville Hydro has indicated that it would not be technically or economically feasible to build a new dedicated feeder to transfer 15 MW of electrical demand between Bronte TS and Glenorchy MTS. This is mainly due to the presence of the Queen Elizabeth Way (“QEW”) highway, which would have to be spanned or tunneled under for a new dedicated connection between the two systems to be made. However, some existing feeders from Bronte TS serve an area north of the QEW, and it is possible to incrementally shift load off these feeders to the adjacent Glenorchy MTS service territory. This would enable new growth to be served elsewhere in the Bronte TS territory, while still respecting existing technical limits.
2. **Trafalgar TS** is approximately 17 km north and east of Bronte TS, and serves Oakville Hydro load exclusively. Load at this station is forecast to remain steady over the next 20 years, and could accommodate up to 40 additional MW of demand. However, 17 km is too far for 27.6 kV distribution feeders to span and supply dense urban loads without a negative impact on voltage. Trafalgar TS is therefore not suitable for either a large or series of small distribution transfers.
3. **Oakville TS #2** is located approximately 10 km east of Bronte TS, and serves load from Oakville Hydro and Enersource (City of Mississauga). This station is forecast to have at least 40 MW of available capacity over the next 20 years. Oakville Hydro has existing emergency transfer capability between Bronte TS and Oakville TS #2, which could be leveraged for short term or small, incremental load transfers. However, Oakville Hydro has indicated that it would not be technically feasible to build a new feeder to perform a single large transfer from Bronte TS to Oakville TS #2 at this time.
4. **Tremaine TS** is located 8 km north and east of Bronte TS, and serves load from Burlington Hydro and Milton Hydro. Under the planning forecast, Tremaine TS is

expected to have at least 80 MW of available capacity over the next 20 years. Both Burlington Hydro and Oakville Hydro have indicated that it would be technically feasible to build new feeders between the Tremaine TS and Bronte service territory to accommodate a large scale load transfer.

Although Oakville Hydro does not currently have load supplied from Tremaine TS, the station is located in close proximity to the Oakville municipal boundary, which would make a full feeder transfer technically feasible. Oakville estimates this transfer would cost \$3.2 million in addition to the cost of an additional breaker which would be required at Tremaine TS, and which Hydro One indicates would likely cost \$1.5-\$2 million. Burlington Hydro estimates that they could move a feeder from Bronte TS to Tremaine TS for \$4.5 million, and would not require an additional breaker to be installed.

A comparison of the four technically feasible wires alternatives are presented in the table below:

**Table 7-1: Summary of Wires Options to Address Bronte Capacity Need**

Option		
Transmission upgrade of B7/B8	<b>\$9.7 million</b>	Increases loading capability at Bronte TS by 14 MW, assuming load can be balanced between buses, at minimal cost.
Feeder transfer to Tremaine TS by Oakville Hydro	<b>\$4.7 million</b> (Comprising \$3.2 million for the 27.6 kV feeder + \$1.5M for a feeder breaker position)	Transferring one feeder from Bronte TS to Tremaine TS enables 15 MW of incremental growth at Bronte TS.  Oakville Hydro does not currently have load supplied by Tremaine TS. Burlington Hydro and Milton Hydro have made capital contributions to Hydro One for the full capacity of Tremaine TS. A commercial agreement between these parties would need to be negotiated and amended to enable Oakville Hydro to transfer load to this station, in accordance with the Transmission System Code.
Feeder transfer to Tremaine TS by Burlington Hydro	<b>\$4.5 million</b> (Comprising \$4.5 million for the 27.6 kV feeder and assuming that	Transferring one feeder from Bronte TS to Tremaine TS enables 15 MW of incremental growth at Bronte TS.  Commercial arrangement would be required between Burlington Hydro and Oakville Hydro as one LDC would be responsible for construction and operation of a low voltage feeder which benefits another.

	<p>an existing feeder position will be leveraged)</p>	<p>Burlington Hydro and Milton Hydro have made capital contributions to Hydro One for the full capacity of Tremaine TS. A commercial agreement between these parties would be required to provide Oakville with access to capacity at Tremaine TS, in accordance with the Transmission System Code.</p> <p>Burlington Hydro has indicated that they may need additional capacity at Bronte in 10 years (beyond what has been included in their load forecast) and capacity allocation to Oakville Hydro would therefore be considered temporary in nature. Under this situation another solution will be required to address this need at that time. The high end for the range of costs is the NPV of performing the Burlington transfer for \$4.5 million today, and the \$4.7 million Oakville transfer in 2028. This results in an overall cost of up to \$7.3M for this scenario<sup>12</sup>.</p>
<p>Smaller, incremental load transfers (as required) – by Oakville Hydro</p>	<p><b>&lt;\$3 million</b></p>	<p>As additional customers are connected within the existing Bronte TS service territory, small adjustments are made to neighbouring station service territories to pick up incremental loads. Total Bronte TS load is limited to 135 MW.</p> <p>Improved transfer capabilities within the Oakville Hydro service territory can improve reliability of affected customers. Costs are estimated to remain under \$3 million, and will emerge through the Distribution System Plan (“DSP”). Costs will also not need to be committed until customer load materializes, and the solution is scalable depending on the size and pace of growth.</p> <p>If at some point it is determined that incremental load transfers are unable to cope with higher than expected growth, an alternative wires solution will be required.</p>

<sup>12</sup> NPV of Oakville solution assumes 2028 in service for both distribution and breaker components. Distribution components assumed to have 70 and 45 years of life, respectively. Real social discount rate of 4%, return on equity of 9.3%.

Although all options have unique factors, the incremental load transfer solution is preferred for the following reasons:

- It is the least cost alternative, with expenditures being incurred incrementally as loads are only shifted when needed to accommodate new growth, while keeping Bronte within its existing capacity rating.
- It eliminates the need for commercial agreements between Burlington Hydro, Oakville Hydro, and Hydro One.
- It has the potential to improve operational flexibility.

Oakville Hydro has indicated that they will be able to keep long term loading at Bronte TS within the acceptable limits primarily through transfers to Glenorchy MTS. Additional details, including necessary investments in switches, feeder ties, and extensions, are to be developed and included through the DSP.

### **7.1.3.3 Infrastructure-based Solution to Address Cooksville West Restoration Need**

Infrastructure, such as a transmission or distribution facility, is typically the only suitable solution to address restoration needs. It provides a means of isolating a faulted section and restoring electrical demand from an alternate source. However, building redundant supply paths can be a high cost solution, depending on the configuration of the local system. Accordingly, ORTAC allows for some discretion when applying this criteria: where a restoration need is identified, “transmission customers and transmitters can consider each case separately taking into account the probability of the contingency, frequency of occurrence, length of repair time, the extent of hardship caused and cost”.<sup>13</sup> Additionally, these parties may also agree on higher or lower levels of reliability for technical, economic, safety and environmental reasons.

Additionally, as described in Section 4.2, a bulk system study is currently underway in West GTA to address overload issues on the 500 kV and some 230 kV transmission assets in the area. The bulk transmission study will investigate major changes to the transmission system. Some local restoration needs (such as the Halton radial pocket (T38/39B), described in Section 6.2.5), are already expected to be addressed through planned system upgrades.

---

<sup>13</sup> ORTAC Section 7.4 Application of Restoration Criteria -

[http://www.ieso.ca/documents/marketAdmin/IMO\\_REQ\\_0041\\_TransmissionAssessmentCriteria.pdf](http://www.ieso.ca/documents/marketAdmin/IMO_REQ_0041_TransmissionAssessmentCriteria.pdf)

Work on the GTA West Bulk System Study is still underway, and final configuration and timing have not yet been determined. As a result, standalone infrastructure solutions to address restoration needs for the West of Cooksville radial pocket will not be further investigated in this IRRP.

If these restoration needs are not adequately addressed through the bulk transmission study, they will be revisited as part of the regional planning process. The criteria outlined in ORTAC (probability of the contingency, frequency of occurrence, length of repair time, the extent of hardship caused and cost) will be considered before a solution is recommended to address this need.

## **7.2 Recommended Near- and Medium-Term Plan**

The Working Group recommends the actions described below to meet the near-term electricity needs of the Bronte Sub-region. Successful implementation of these actions, in addition to achievement of targeted conservation measures, is expected to address the sub-region's electricity needs until the early 2030s.

1. Oakville Hydro to perform small, incremental load transfers from Bronte TS to adjacent station service territories (primarily Glenorchy MTS) as new customer connections are made, or as loads increase. This action should be initiated as soon as necessary to prevent the risk of thermal overloads on B7/B8 and post contingency voltage drop at Bronte TS. The implementation details for this solution will be carried out through a DSP.
2. Pursue economic options to offset new load growth in the Bronte TS service area with CDM (including DR), and investigate opportunities for local generation, including CHP projects, where cost effective. In order to defer further long-term "wires" investments, total peak demand at Bronte TS must be kept below 135 MW.

If load at Bronte TS cannot be kept below 135 MW, additional "wires" infrastructure will be required. The preferred option would likely be a feeder transfer from Bronte TS to a neighbouring supply station, but given the long-term nature of this need, the preferred options should be re investigated with consideration of the system in place at that time.

### 7.3 Implementation of Near- and Medium-Term Plan

To ensure that the near-term electricity needs of Bronte Sub-region are addressed, it is important that the plan recommendations be implemented as soon as possible. The specific actions and deliverables are outlined in Table 7-2, along with the recommended timing.

**Table 7-2: Summary of Needs and Recommended Actions in Bronte Sub-region**

Need	Recommended Action	Need Date
Overloads on B7/B8 circuits (2018), post contingency voltage drop at Bronte TS (2021)	Oakville Hydro to perform ongoing incremental load transfers from Bronte TS to adjacent station service territories (primarily Glenorchy MTS). Peak demand at Bronte TS to be kept under 135 MW.	2018
Ongoing load growth on Bronte TS potentially triggering same needs in the medium to long term	Pursue economic peak demand reducing measures, including CDM and DG, to keep Bronte TS demand below 135 MW.	ongoing

The implementation details for this solution will be carried out through a DSP. Actual loads at Bronte TS will be monitored on an annual basis, and the planning process may be initiated if required.



## 8. Long-Term Plan

Based on the electrical demand forecasts provided by Burlington Hydro and Oakville Hydro, implementation of the recommended near-term plan is expected to address long-term needs in the Bronte Sub-region until the early 2030s. Due to the inherent uncertainty associated with producing long-term load forecasts, there is potential that additional load could materialize within the Bronte TS service territory, potentially exceeding the load meeting capability. The solutions available to address this potential risk are dependent on the magnitude and pace of the longer-term electrical demand which may materialize.

If the magnitude and pace of growth in electrical demand is moderate in nature (up to 1.5% per year gross), it is likely that the needs over the next 20 years will be small and manageable. The anticipated needs (small in scale, spread out over many customers, and driven more by intensification than by significant new greenfield developments) are well suited to community driven solutions. This may include implementation of local distributed energy resource projects (such as small scale CHP, solar and/or storage technologies) or targeted conservation initiatives that contribute to peak demand reduction (such as DR programs). Identifying potential candidate projects or initiatives should be part of the ongoing planning and engagement process between the Working Group, local communities/ municipalities, and other stakeholders in the area. The development of local Community Energy Plans provide a valuable resource for aligning the local electricity needs with municipal goals and objectives, where appropriate.

In the event that the magnitude and pace of growth in electrical demand is higher (over 2% per year gross), an infrastructure solution may be required. Such increased demand could be the result of a single new customer (such as a data centre), changing demand profiles of existing customers (for example, as a result of widespread adoption of electrification technologies), or a combination of these factors. Given the high relative cost of a transmission system upgrade, it is likely that a distribution feeder transfer to a nearby station will be the most cost effective solution for addressing long term needs, but this assumption should be revisited in the future as changes to system configurations and development of local technologies may occur in the interim.

Burlington Hydro has indicated that there is potential for longer-term growth in the Bronte TS service area, pending updates to the Regional and Municipal growth plans. As a result, there may be a longer-term need for incremental capacity to serve Burlington Hydro customers. In

the event that this demand triggers additional needs, this study should be revisited to investigate the most efficient options, including the opportunity for a common solution.

The Working Group will work with the local communities to monitor leading indicators for growth in the Bronte Sub-region. This includes monitoring changes to growth targets, the composition and location of specific customer segments (residential, commercial, industrial) and effects on electricity related to the implementation of community energy plans. If these or other factors impact service reliability or capacity of the local electricity delivery systems a new IRRP process may be initiated ahead of the 5 year planning cycle. The potential for other measures, such as incremental DG or DR programs, will continue to be discussed through engagement with local municipalities, and in particular as the nature of the long-term needs, alternatives, and associated costs become clearer.

## 9. Engagement Activities

Keeping communities up-to-date on regional electricity planning is important. For the Bronte IRRP, this included meetings with the City of Burlington and the Town of Oakville to share the needs identified in the regional plan and the actions being undertaken by the IESO, Transmission Company and LDCs to ensure a reliable and economic level of service is maintained. The meetings also provided an opportunity to begin discussions with the municipalities on planning for the longer term. While no longer-term needs have been identified for the Bronte Sub-region in this planning cycle, discussions that take place now on community energy planning and municipal sustainability initiatives will help to inform future electricity plans and bring all of these processes closer together.

While this dialogue for the longer-term continues with municipalities and communities, and as future planning initiatives unfold, the Working Group will engage in accordance with the established community engagement principles.<sup>14</sup> Any updates will be posted on the dedicated Bronte planning webpage<sup>15</sup> on the IESO website. Since the Bronte planning area includes part of the broader Burlington to Nanticoke, and the GTA West planning regions, updates will be sent to all subscribers who have requested updates on these regions.

---

<sup>14</sup> <http://www.ieso.ca/Pages/Participate/Regional-Planning/default.aspx>

<sup>15</sup> <http://www.ieso.ca/Pages/Ontario%27s-Power-System/Regional-Planning/Burlington-to-Nanticoke/Bronte.aspx>

## 10. Conclusion

This report documents an IRRP that has been carried out for the Bronte area, a sub-region of the OEB's Burlington-Nanticoke planning region. The IRRP identifies electricity needs in the Bronte Sub-region over the 20-year period from 2015-2034, identifies a preferred distribution level "wires" solution to address near-term needs, and lays out actions to monitor, defer, and address needs that may arise in the long term.

The next phase of the Regional Planning Process is the development of a RIP. The RIP is to be led by Hydro One Transmission and include Burlington Hydro and Oakville Hydro as working group members.

The IESO will continue to provide support throughout the RIP process, and assist with any regulatory matters which may arise as challenges to plan implementation.

The Bronte Sub-region Working Group will continue to meet at regular intervals to monitor developments in the sub-region and to track progress toward the plan deliverables. In particular, the actions and deliverables associated with peak demand reducing initiatives will require annual review of system demand and program achievement to determine whether new initiatives are required. In the event that underlying assumptions change significantly, local plans may be revisited through an amendment, or by initiating a new regional planning cycle sooner than the OEB-mandated 5-year schedule.