

# Market Manual

---

## **Market Manual 1: Connecting to Ontario's Power System**

# **Part 1.7: Synchrophasor Data Requirements**

---

**Issue 2.1**  
**December 3, 2025**

*This document provides detailed procedures to be followed by connection applicants who wish to connect to the IESO-controlled grid.*



## Document Change History

Issue	Reason for Issue	Date
Refer to Issue 1.0 (PRO-723) for changes prior to Market Transition.		
1.0	Market transition	April 4, 2025
2.0	Issued for Baseline 54.1	December 3, 2025
2.1	Issued as part of Updates to IESO Monitoring Requirements	December 10, 2025

## Related Documents

Document ID	Document Title
RUL-11	Market Rules Chapter 2: Grid Connection Requirements
RUL-12	Market Rules Chapter 2: Grid Connection Requirements – Appendices
RuL-24	Market Rules Chapter 11: Definitions

# Table of Contents

<b>Table of Contents</b> .....	<b>i</b>
<b>List of Figures</b> .....	<b>ii</b>
<b>List of Tables</b> .....	<b>iii</b>
<b>Table of Changes</b> .....	<b>iv</b>
<b>Market Manual Conventions</b> .....	<b>1</b>
1 Introduction.....	2
1.1 Purpose .....	2
1.2 Scope .....	2
1.3 Contact Information .....	3
2 Requirements: Generators .....	4
2.1 Infrastructure Requirements for Generators .....	4
2.2 Phasor Data Requirements for Generators.....	5
2.3 Applicable Generator Connection Configurations .....	10
2.4 Reliability, Maintenance and Repair .....	11
2.5 Low Capacity Factor .....	11
3 Requirements: Transmitters.....	12
3.1 Infrastructure Requirements for Transmitters .....	12
3.2 Phasor Data Requirements for Transmitters.....	12
3.3 Reliability, Maintenance and Repair .....	18
4 Requirements: Electricity Storage Participants .....	19
4.1 Infrastructure Requirements for Electricity Storage Participants..	19
4.2 Phasor Data Requirements for Electricity Storage Participants ....	20
4.3 Applicable Electricity Storage Units Connection .....	24
4.4 Reliability, Maintenance and Repair .....	24
5 PMU Registration Process .....	25
6 PMU Connection Process .....	29
7 Background Information for Synchrophasors and Associated Infrastructure .....	31
7.1 Typical Infrastructure for Providing Synchrophasor Data .....	31

## List of Figures

Figure 2-1: Examples for synchrophasor data measurement locations for different generator connection configurations.....	11
Figure 4-1: Examples of synchrophasor data measurement locations for different electricity storage facilities and PMU connection configurations .....	24
Figure 4-1: PMU Registration Process .....	26
Figure 4-2: Sample PMU Registration Form to be completed. Download PMU Registration Form from IESO website .....	27
Figure 4-3: Sample PDC Registration Form to be completed. Download the PMU Registration Form from IESO website. ....	28
Figure 5-1: Typical infrastructure required for providing synchrophasor data (single PMU) .....	31
Figure 5-2: Typical infrastructure for multiple PMUs .....	31
Figure 5-3: PMU and Phasor Data Concentrators.....	31
Figure 5-4: AC waveform during dynamics .....	31



## List of Tables

Table 2-1: Requirements for Generators.....	5
Table 3-1: Requirements for Transmitters.....	13
<b>Table 4-1: Requirements for Electricity Storage Units .....</b>	<b>20</b>



# Table of Changes

<b>Reference</b>	<b>Description of Change</b>
Section 4	New section to outline requirements for electricity storage facilities
Section 6	New section to outline PMU connection process
Throughout	Reformatting to post-MRP template and conventions

# Market Manuals

*Market manuals* set out procedural and administrative details with respect to *market rule* requirements. Where there is a conflict between the requirements described in a *market manual* or appended document, and those within the *market rules*, the *market rules* shall prevail.

## Market Manual Conventions

The standard conventions followed for market manuals are as follows:

- The word 'shall' denotes a mandatory requirement;
- References to *market rule* sections and sub-sections may be abbreviated in accordance with the following representative format: '**MR Ch.1 ss.1.1-1.2**' (i.e. *market rules*, Chapter 1, sections 1.1 to 1.2).
- References to *market manual* sections and sub-sections may be abbreviated in accordance with the following representative format: '**MM 1.5 ss.1.1-1.2**' (i.e. *market manual* 1.5, sections 1.1 to 1.2).
- Internal references to sections and sub-sections within this manual take the representative format: 'sections 1.1 – 1.2'
- Terms and acronyms used in this *market manual* and its appended documents that are italicized have the meanings ascribed thereto in **MR Ch.11**;
- All user interface labels and options that appear on the IESO gateway and tools are formatted with the bold font style; and
- Data fields are identified in all capitals.

– End of Section –

– End of Section –

# 1 Introduction

## 1.1 Purpose

This *market manual* elaborates on *synchrophasor* data requirements for:

- 1) *Generation facilities* connected to the *IESO-controlled grid*, as documented in MR Ch.4 App. 4.15;
- 2) *Transmission systems* connected to the *IESO-controlled grid*, as documented in MR Ch.4 App. 4.16; and
- 3) *Electricity storage facilities* connected to the *IESO-controlled grid*, as documented in MR Ch. App. 4.24.

Sections 2, 3, and 4 include technical specifications and guidelines for *generators*, *transmitters*, and *electricity storage participants* for supplying *synchrophasor* data with the required attributes to the IESO for utilization in planning and operation of the *IESO-controlled grid*. Section 5 and 6 includes the process of registering Phasor Measurement Units (*PMUs*) with the *IESO* before a connection can be established for the transmission of *synchrophasor* data and the process for connecting *PMUs*.

## 1.2 Scope

This *market manual* supplements the following *market rules*:

- MR Ch.4 s.7.2: Provision of Connection-Related Information
- MR Ch. App. 4.15: IESO Monitoring Requirements: *Generators*
- MR Ch. App. 4.16: IESO Monitoring Requirements: *Transmitters*
- MR Ch. App. 4.24: IESO Monitoring Requirements: *Electricity storage participants*

*Synchrophasor* data is primarily generated by dedicated devices. However, *synchrophasor* data can also be produced by other multi-purpose devices that incorporate *synchrophasor* data capabilities such as (1) modern Dynamic Disturbance Recorders or (2) Intelligent Electronic Devices used for protection. The technical requirements and functionalities of those devices are unique and materially different to each other. The scope of this *market manual* does not include technical requirements of those devices but is instead focused on clarifying the technical requirements of the *synchrophasor* data that any of those devices, each considered to be a *phasor measurement unit (PMU)*, must produce to meet the *IESO's* requirements.

The *synchrophasor* data from the *PMU* devices may be transmitted to the *IESO* via a processor called the Phasor Data Concentrator (PDC). The technical requirements of the PDC are also not in the scope of this *market manual*.

## 1.3 Contact Information

Changes to this *market manual* are managed via the IESO Change Management process. Stakeholders are encouraged to participate in the evolution of this *market manual* via this process. To contact the *IESO*, you can email IESO Customer Relations at [customer.relations@ieso.ca](mailto:customer.relations@ieso.ca) or use telephone or mail. Telephone numbers and the mailing address can be found on the *IESO* website. IESO Customer Relations staff will respond as soon as possible.

**– End of Section –**

## 2 Requirements: Generators

### 2.1 Infrastructure Requirements for Generators

(MR Ch. 4 App.4.15)

*Market participants* are expected to follow NERC's IRO-010-3 standard as described in MM 11.1 s.7 when providing *synchrophasor* data to the *IESO* which will be used for situational awareness and planning analyses purposes. In cases where the *synchrophasor* data will be provided from devices already classified as a BES Cyber Asset then the data and its associated infrastructure must comply with *NERC* Critical Infrastructure Protection (CIP) program.

Transmission of *synchrophasor* data to the *IESO* must occur over the internet using a secure IPsec site-to-site VPN connection with the following specifications:

- 1) Internet connection with bandwidth and latency specifications as per **Table 2-1**;
- 2) Public static IP address; and
- 3) Firewall device capable of creating IPsec site-to-site VPN tunnel with the following settings: IKEv2, AES-256 Encryption, SHA256 Data Integrity, 2048 bit DH group, PFS with 2048 bit DH group.

In certain circumstances, the *IESO* may permit the use of a private communication link instead of a public internet-based VPN connection. Approval for such arrangements can be requested at the time of *PMU* registration via e-mail submissions at [PMUregistration@ieso.ca](mailto:PMUregistration@ieso.ca). The *IESO* has the sole discretion in approving such arrangements and will evaluate each request on a case-by-case basis.

## 2.2 Phasor Data Requirements for Generators

(MR Ch. 4 App.4.15)

The *IESO* may, at its discretion, require *generators* to provide *synchrophasor* data for reliability and system awareness purposes. Such need will be informed by considerations such as proximity to other *synchrophasor* measurement units, criticality of the *facility* from system stability perspective, etc. If the *IESO* determines that *synchrophasor* data is required from a *generation facility* for reliability and system awareness purposes, the *IESO* shall notify the *market participant* of such requirement.

If a *market participant* is required to provide **and/or update** *synchrophasor* data to the *IESO* in respect of multiple *facilities* commencing in the same calendar year, such *market participant* can email IESOCustomerRelations@ieso.ca to request a staged implementation plan. The *IESO* may permit a staged implementation plan, the specific terms of which will be subject to mutual agreement.

Table 2-1 sets forth the *synchrophasor* data requirements relating to a *generation facility*.

**Table 2--1: Requirements for Generators<sup>1</sup>**

Attribute	Status	Requirement
Measurement Point	Required	<p>Requirements (1) and (2) pertain to <i>generation facilities</i> that are directly <i>connected</i> to a Bulk Power System (BPS) Station OR have a <i>connection point</i> voltage greater than 200 kV.</p> <p>(1) For any single <i>generation unit</i> rated equal to or greater than 100 MVA name-plate rating, provide <i>synchrophasor</i> data measured at generator terminal (i.e. low side of the generator output transformer). <i>Generation facilities</i> in operation prior to December 31, 2024 that have disturbance monitoring equipment on the high side of the <i>generator</i> output transformer may provide <i>synchrophasor</i> data from those existing measuring locations. See configuration 1 of <b>Figure 2-1</b>.</p> <p>(2) Multiple <i>generation units</i> that have an aggregate name-plate rating that is equal to or greater than 100 MVA,</p>

<sup>1</sup> Specifications noted as “required” must be satisfied, specifications noted as “preferred” are not required but add additional operational value and should be satisfied wherever practical.

Attribute	Status	Requirement
-----------	--------	-------------

must provide *synchrophasor* data measured at the *generation facility* side of each point of connection to the *IESO-controlled grid*. See configurations 2, 3, 4 of **Figure 2-1**. Alternatively, other measuring locations of *synchrophasor* data inside the *generation facility* can be provided if they allow for calculating the aggregated *synchrophasor* data at the *generation facility* side of each point of connection. See configurations 2, 3, 4 of **Figure 2-1**.

- (3) *Generation facilities* subject to (1) and (2) above will not be required to provide the *synchrophasor* data if the *IESO* determines, in its sole discretion, that they meet one of the following criteria:
- (a) The *generation facility* is expected to be deregistered by December 31, 2029; or
  - (b) The annual gross capacity factor of the *generation facility* meets the requirements as stipulated in **Section 2.5**.

If the *IESO* determines that a *generation facility* meets such criteria, it shall notify the *generator* of such determination and such determination remains subject to the *IESO's* periodic review and assessment of the decommissioning plan and evaluation of capacity factor and can be revoked at the *IESO's* discretion by providing the *generator* with notice of such new determination.

If the *IESO* revokes its determination, and subject to the possibility of an *IESO*-approved staged implementation plan in accordance with section 2.2, the *generation facility* will be required to provide the *synchrophasor* data within 3 years from the notification date.

All *generation units* whose output power flow contributes to an Interconnection Reliability Operating Limit (IROL) definition<sup>3</sup>, regardless of rated size, must provide voltage and

---

<sup>3</sup> *Market Participants* should contact the *IESO* if they need assistance determining whether their plant is part of an IROL.

Attribute	Status	Requirement
		current phasor for all three phases and frequency at the terminals defining the IROL.
Measurement Point	Preferred	Provide additional <i>synchrophasor</i> data from a <i>generation facility</i> for specific <i>reliability</i> needs (e.g. <i>generation facility</i> with history of oscillatory events or to achieve sufficient observability over the <i>IESO-controlled grid</i> ).
Measured Quantities	Required	Provide the following for all 3 phases the voltage magnitude (Volts or kV) and voltage phasor angle (degrees), for all 3 phases the current phasor magnitude (Amperes or kA), and current phasor angle (degrees), frequency (Hz) and rate of change of frequency (ROCOF).
Coordinates	Required	Provide phasor data in polar coordinates where magnitudes must be in SI units.
System Frequency	Required	Provide phasor data continuously at frequency between 57 Hz and 62 Hz.
Reporting Rate	Required	Provide <i>synchrophasor</i> data at least once in every one sixtieth of a second (i.e. 60 samples per second).
Time-Tag Format and Accuracy	Required	All <i>synchrophasor</i> data shall be reported in Coordinated Universal Time (UTC time) with zero offset. For each phasor measurement, data shall include a time tag traceable to UTC clock that includes the time and time quality at the time of measurement. The time tag shall accurately resolve time of measurement to at least 1 $\mu$ s within a specified 100-year period.
Data Format and Accuracy Standard	Required	Data provided to the <i>IESO</i> shall comply with the IEEE Std 60255-118-1-2018. Notwithstanding the foregoing, <i>market participants</i> connected to the <i>IESO-controlled grid</i> with <i>synchrophasor</i> data measurement infrastructure meeting IEEE Std C37.118 (2005, 2011, or 2014) and operating as

Attribute	Status	Requirement
		part of the <i>IESO-administered markets</i> prior to December 31 2024, the <i>market participant</i> may use such existing measurement infrastructure for the remainder of its expected useful life.
Network Protocol	Required	Provide <i>synchrophasor</i> data via a site-to-site VPN with the <i>IESO</i> . A public static IP address is required.
Instrumentation Channel	Required	Provide instrument transformers and its corresponding instrumentation channel components with accuracy high enough to be appropriately utilized in <i>IESO</i> real-time applications <sup>(4)</sup> .
Latency	Required	Provide total latency for <i>synchrophasor</i> data from <i>PMU</i> to the <i>IESO</i> control center or <i>IESO</i> owned PDC no more than 500 ms. The <i>market participant</i> shall be required to provide latency of no more than a 100 ms if informed by the <i>IESO</i> that its <i>synchrophasor</i> data is to be used in a Linear State Estimator as part of a Transient Stability program.
Latency	Preferred	Provide total latency for <i>synchrophasor</i> data from <i>PMU</i> to the <i>IESO</i> control center or <i>IESO</i> owned PDC no more than 100 ms.
Bandwidth	Required	Provide communication channels with bandwidth adequate to reliably transmit the volume of <i>PMU</i> data at the required reporting rate. For most <i>generation facilities</i> a bandwidth of 1 Mbps per transmitting <i>PMU</i> device will be sufficient.
Bandwidth	Preferred	Provide dedicated communication channels.

<sup>4</sup> This requirement intends to provide flexibility to *market participants* to utilize their current Instrumentation Channel infrastructure with minimum accuracy equal or better than those used for *SCADA* measurements.

Attribute	Status	Requirement
Critical Infrastructure Protection (CIP)	Preferred	<i>Market participants</i> to include <i>synchrophasor</i> data under their <i>NERC</i> Critical Infrastructure Protection (CIP) program.
		Provide primary communication path for <i>synchrophasor</i> data to the <i>IESO</i> .
Redundancy	Required	The <i>market participant</i> shall be required to provide primary and secondary communication paths for <i>synchrophasor</i> data if informed by the <i>IESO</i> that its data is to be used in a Linear State Estimator as part of a Transient Stability program.
Redundancy	Preferred	Provide primary and secondary communication paths for <i>synchrophasor</i> data to the <i>IESO</i> ,
CVT/PT Selection	Preferred	Provide Metering Class Bus CVT or PT measurements where possible or Metering Class Transmission line or feeder CVT/PT measurements for better accuracy.
CT Selection	Preferred	Provide Protection Class CTs measurements where possible to capture the dynamic and fault conditions.

## 2.3 Applicable Generator Connection Configurations

(MR Ch.4 s.7.2)

Figure 2-1 illustrates measurement points for applicable *generation facilities*.

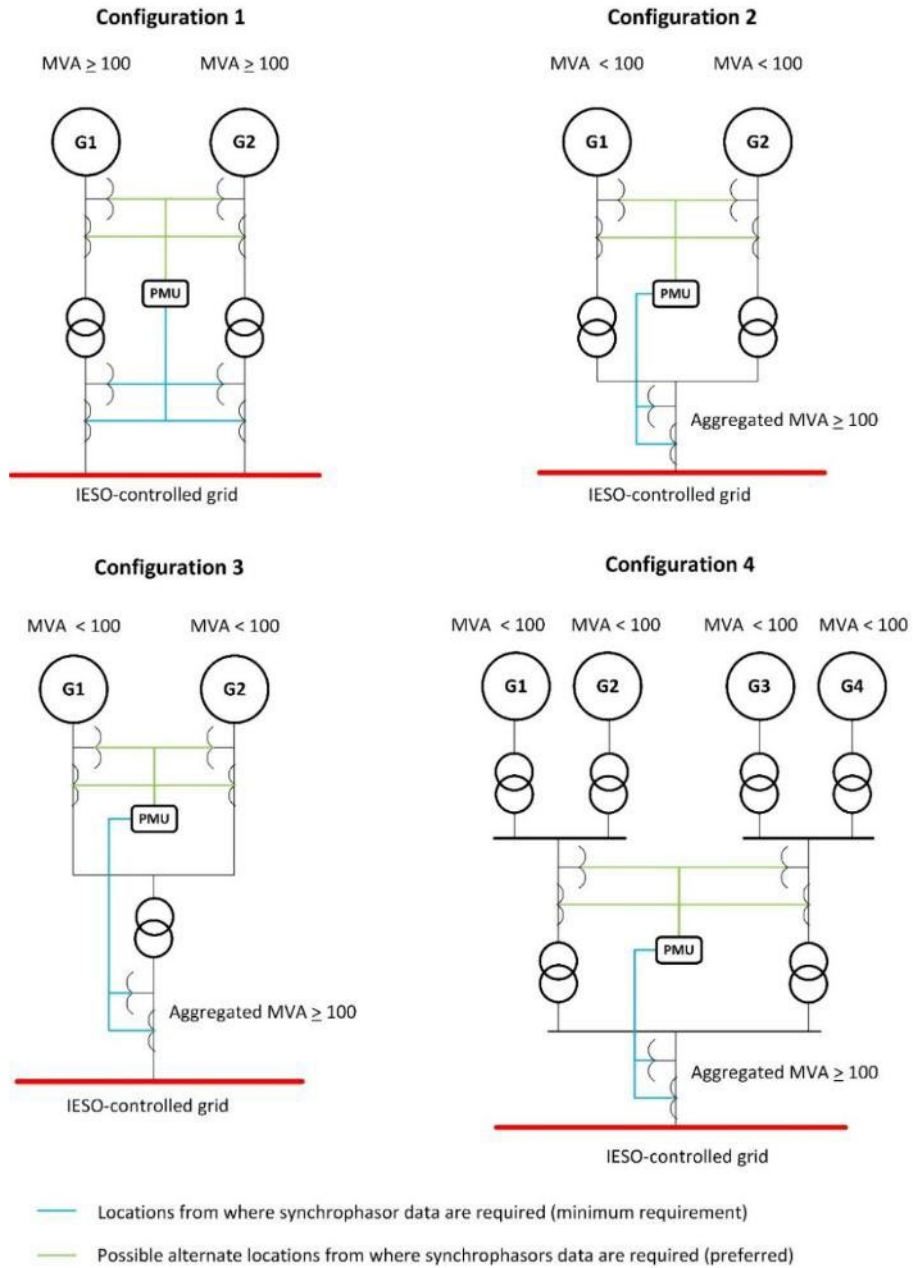

**Figure 2-1:** Examples for synchrophasor data measurement locations for different generator connection configurations.

## 2.4 Reliability, Maintenance and Repair

(MR Ch.4 s.7.7)

MR Ch. 4, Sec. 7.7, is applicable to installed *synchrophasor* data devices and associated required infrastructure including instrument transformers, communication channels and PDCs.

## 2.5 Low Capacity Factor

MR Ch. 4 App.4.15)

This section explains the process for identifying *generation units* that are excluded from *synchrophasor* data requirements due to a Capacity Factor (CF) below 10%. When the *IESO* determines that a *generation unit* has a CF less than 10%, such *generation unit* will not be required to provide the *IESO* with *synchrophasor* data until otherwise directed by the *IESO*.

At least once a year the *IESO* will calculate the annual average CF using historical data for the last 3 years or since the in-service date, whichever is less, only for *generation units* that had CF below 10% in all prior assessments. Upon performing the annual assessment, if the CF for a *generation unit* is greater than or equal to 10%, the *IESO* will notify the *facility* owner that:

- The exclusion from *synchrophasor* requirements is no longer valid
- The *generation unit* will no longer be included for future annual CF assessments
- *Synchrophasor* data must be provided to the *IESO* within 3 years from the notification date. *Market participants* having multiple *facilities* whose CF becomes greater than or equal to 10% in the same year, may provide *synchrophasor* data via mutually agreed staged implementation plan, if required.

Future generation projects will be assessed during the connection approval process to determine if they qualify for exclusion from the *synchrophasor* requirements.

– End of Section –

## 3 Requirements: Transmitters

### 3.1 Infrastructure Requirements for Transmitters

(MR Ch. 4 App.4.16)

*Market participants* are expected to follow NERC's IRO-010-3 standard as described in MM 11.1 s.7 when providing *synchrophasor* data to the IESO which will be used for situational awareness and planning analyses purposes. In cases where the *synchrophasor* data will be provided from devices already classified as a BES Cyber Asset then the data and its associated infrastructure must comply with *NERC* Critical Infrastructure Protection (CIP) program.

Transmission of *synchrophasor* data to the *IESO* must occur over the internet using a secure IPsec site-to-site VPN connection with the following specifications:

- 1) Internet connection with bandwidth and latency specifications as per **Table 2-1**;
- 2) Public static IP address; and
- 3) Firewall device capable of creating IPsec site-to-site VPN tunnel with the following settings: IKEv2, AES-256 Encryption, SHA256 Data Integrity, 2048 bit DH group, PFS with 2048 bit DH group.

In certain circumstances, the IESO may permit the use of a private communication link instead of a public internet-based VPN connection. Approval for such arrangements can be requested at the time of PMU registration via e-mail submissions at [PMUregistration@ieso.ca](mailto:PMUregistration@ieso.ca). IESO has the sole discretion in approving such arrangements and will evaluate each request on a case-by-case basis.

### 3.2 Phasor Data Requirements for Transmitters

(MR Ch. 4 App.4.16)

The *IESO* may, at its discretion, require *transmitters* to provide *synchrophasor* data for reliability and system awareness purposes. Such need will be informed by considerations such as proximity to other *synchrophasor* measurement units, criticality of the *facility* from system stability perspective, etc. If the *IESO* determines a transmission *facility* is required to provide *synchrophasor* data for reliability and system awareness purposes, the *IESO* shall notify the *market participant* of such requirement.

If a *market participant* is required to provide **and/or update** *synchrophasor* data to the *IESO* in respect of multiple *facilities* commencing in the same calendar year, such *market participant* can email IESOCustomerRelations@ieso.ca to request a staged implementation plan. The *IESO* may permit a staged implementation plan, the specific terms of which will be subject to mutual agreement.

Table 3-1 sets forth the *synchrophasor data* requirements relating to transmission *facilities*.

**Table 3-1: Requirements for Transmitters<sup>5</sup>**

Attribute	Status	Requirement
Measurement Points and quantities	Required	<p>Two separate 500 kV buses in 500 kV stations, two separate BPS-classified buses in BPS stations, two separate buses in stations that are required to restore the grid from black-start units. <b>Provide the following for all 3 phases the voltage magnitude (Volts or kV) and voltage phasor angle (degrees), frequency (Hz) and rate of change of frequency (ROCOF)</b></p> <p>Terminals of circuits defining Interconnection Reliability Operating Limits (IROL) and Inerties. <b>Provide the following for all 3 phases the voltage magnitude (Volts or kV) and voltage phasor angle (degrees), for all 3 phases the current phasor magnitude (Amperes or kA), and current phasor angle (degrees), frequency (Hz) and rate of change of frequency (ROCOF)</b></p>

<sup>5</sup> Specifications noted as “required” must be satisfied, specifications noted as “preferred” are not required but add additional operational value and should be satisfied wherever practical.

Attribute	Status	Requirement
		Terminal bus of Static Var Compensators (SVC), synchronous condensers and static synchronous compensators (STATCOM). <u>Provide the following for all 3 phases the voltage magnitude (Volts or kV) and voltage phasor angle (degrees), for all 3 phases the current phasor magnitude (Amperes or kA), and current phasor angle (degrees), frequency (Hz) and rate of change of frequency (ROCOF)</u>
Coordinates	Required	Provide phasor data in polar coordinates where magnitudes must be in SI units.
System Frequency	Required	Provide phasor data continuously at frequency between 57 Hz and 62 Hz.
Reporting Rate	Required	Provide <i>synchrophasor</i> data at least once in every one sixtieth of a second (i.e. 60 samples per second).
Time-Tag Format and Accuracy	Required	All <i>synchrophasor</i> data shall be reported in Coordinated Universal Time (UTC time) with zero offset. For each phasor measurement, data shall include a time tag traceable to UTC clock that includes the time and time quality at the time of measurement. The time tag shall accurately resolve time of measurement to at least 1 microsecond within a specified 100-year period.

Attribute	Status	Requirement
Data Format and Accuracy Standard	Required	Data provided to the <i>IESO</i> shall comply with the IEEE Std 60255-118-1-2018. Notwithstanding the foregoing, <i>market participants</i> connected to the <i>IESO-controlled grid</i> with <i>synchrophasor</i> data measurement infrastructure meeting IEEE Std C37.118 (2005, 2011, or 2014) and operating as part of the IESO-administered market prior to December 31, 2024 the <i>market participant</i> may use such existing measurement infrastructure for the remainder of its expected useful life..
Network Protocol	Required	Provide <i>synchrophasor</i> data via a site-to-site VPN with the <i>IESO</i> . A public static IP address is required.
Instrumentation Channel	Required	Provide instrument transformers and its corresponding instrumentation channel components with accuracy high enough to be appropriately utilized in <i>IESO</i> real-time applications <sup>(6)</sup> .
Latency	Required	Provide total latency for <i>synchrophasor</i> data from <i>PMU</i> to the <i>IESO</i> control center or <i>IESO</i> owned PDC no more than 500 ms. The <i>market participant</i> shall be required to provide latency of no more than a 100 ms if informed by the <i>IESO</i> that its <i>synchrophasor</i> data is to be used in a Linear State Estimator as part of a Transient Stability program.
Latency	Preferred	Provide total latency for <i>synchrophasor</i> data from <i>PMU</i> to the <i>IESO</i> control center or <i>IESO</i> owned PDC no more than 100 ms.

<sup>6</sup> This requirement intends to provide flexibility to *market participants* to utilize their current Instrumentation Channel infrastructure with minimum accuracy equal or better than those used for *SCADA* measurements.

Attribute	Status	Requirement
Bandwidth	Required	<p>Provide communication channels with bandwidth adequate to reliably transmit the volume of <i>PMU</i> data at the required reporting rate.</p> <p>For most transmission <i>facilities</i> a bandwidth of 1 Mbps per transmitting <i>PMU</i> device will be sufficient.</p>
Bandwidth	Preferred	<p>Provide dedicated communication channels to avoid any data transmission interruption and excessive latency.</p>
Circuit Breaker Status	Preferred	<p>Provide Circuit Breaker Status (Digital Channels) of all transmission lines or feeders for Linear State Estimator Estimation, and for Single Line Diagram topological display purposes</p> <p>This may become a requirement in the future as the <i>IESO</i> deploys <i>PMUs</i> into real-time operations.</p> <p>Note that this data supports industry best practice to collect this data directly from <i>PMUs</i> to reduce dependencies and provide a solution for state estimation when <i>SCADA</i> is not available.</p>
Isolator Status	Preferred	<p>Provide Isolator Status (Digital Channels) of all transmission lines or feeders for Linear State Estimator Estimation, and for Single Line Diagram topological display purposes.</p> <p>This may become required in the future as the <i>IESO</i> deploys <i>PMUs</i> into real-time operations.</p> <p>Note that this data supports industry best practice to collect this data directly from <i>PMUs</i> to reduce dependencies and provide a solution for state estimation when <i>SCADA</i> is not available.</p>

<b>Attribute</b>	<b>Status</b>	<b>Requirement</b>
CVT/PT Selection	Preferred	Provide Metering Class Bus CVT or PT measurements where possible or Metering Class Transmission line or feeder CVT/PT measurements for better accuracy.
CT Selection	Preferred	Provide Protection Class CTs measurements where possible to capture the dynamic and fault conditions.

### 3.3 Reliability, Maintenance and Repair

(MR Ch.4 s.7.7)

MR Ch. 4, Sec. 7.7, is applicable to installed *synchrophasor* data devices and associated required infrastructure including instrument transformers, communication channels and PDCs.

**– End of Section –**

## 4 Requirements: Electricity Storage Participants

### 4.1 Infrastructure Requirements for Electricity Storage Participants

(MR Ch. 4 App.4.24)

*Market participants* are expected to follow NERC's IRO-010-3 standard as described in MM 11.1 s.7 when providing *synchrophasor* data to the *IESO* which will be used for situational awareness and planning analyses purposes. In cases where the *synchrophasor* data will be provided from devices already classified as a BES Cyber Asset then the data and its associated infrastructure must comply with *NERC* Critical Infrastructure Protection (CIP) program.

Transmission of *synchrophasor* data to the *IESO* must occur over the internet using a secure IPsec site-to-site VPN connection with the following specifications:

- 1) Internet connection with bandwidth and latency specifications as per **Table 2-1**;
- 2) Public static IP address; and
- 3) Firewall device capable of creating IPsec site-to-site VPN tunnel with the following settings: IKEv2, AES-256 Encryption, SHA256 Data Integrity, 2048 bit DH group, PFS with 2048 bit DH group.

In certain circumstances, the *IESO* may permit the use of a private communication link instead of a public internet-based VPN connection. Approval for such arrangements can be requested at the time of PMU registration via e-mail submissions at [PMUregistration@ieso.ca](mailto:PMUregistration@ieso.ca). The *IESO* has the sole discretion in approving such arrangements and will evaluate each request on a case-by-case basis.

## 4.2 Phasor Data Requirements for Electricity Storage Participants

(MR Ch. 4 App.4.24)

The IESO may, at its discretion, require *electricity storage participants* to provide *synchrophasor* data for reliability and system awareness purposes. Such need will be informed by considerations such as proximity to other *synchrophasor* measurement units, criticality of the *facility* from system stability perspective, etc. If the IESO determines an *electricity storage facility* is required to provide *synchrophasor* data for reliability and system awareness purposes, the IESO shall notify the *market participant* of such requirement.

Table 4-1 sets forth the synchrophasor data requirements relating to an *electricity storage facility*.

**Table 4-1: Requirements for Electricity Storage Units<sup>7</sup>**

Attribute	Status	Requirement
Measurement Point	Required	<p>Requirements (1) and (2) pertain to <i>electricity storage units</i> that are directly <i>connected</i> to a Bulk Power System (BPS) Station OR have a <i>connection point</i> voltage greater than 200 kV.</p> <p>(1) For any single <i>electricity storage unit</i> rated equal to or greater than 20 MVA name-plate rating, provide <i>synchrophasor</i> data measured at electricity storage units terminal (i.e. low side of the generator output transformer). See configuration 1 of <b>Figure 4-1</b>.</p> <p>(2) Multiple <i>electricity storage units</i> that in aggregate equal to or greater than 20 MVA name-plate rating, must provide <i>synchrophasor</i> data measured at the <i>electricity storage unit's facility</i> side of each point of connection to the <i>IESO-controlled grid</i>. See configuration 2 <b>Figure 4-1</b>. Alternatively, other measuring locations of <i>synchrophasor</i></p>

<sup>7</sup> Specifications noted as "required" must be satisfied, specifications noted as "preferred" are not required but add additional operational value and should be satisfied wherever practical.

data inside the *facility* can be provided if they allow for calculating the aggregated *synchrophasor* data at the *electricity storage unit's facility* side of each point of connection. See configurations of **Figure 4-1**.

For all *electricity storage units* whose output power flow contributes to an Interconnection Reliability Operating Limit (IROL) definition, regardless of rated size, must provide voltage and current phasor for all three phases and frequency at the terminals defining the IROL.

Measurement Point	Preferred	Provide additional <i>synchrophasor</i> data from an <i>electricity storage facility</i> for specific <i>reliability</i> needs (e.g. <i>electricity storage facility</i> with history of oscillatory events or to achieve sufficient observability over the <i>IESO-controlled grid</i> ).
Measured Quantities and Units	Required	Provide the following for all 3 phases the voltage magnitude (Volts or kV) and voltage phasor angle (degrees), for all 3 phases the current phasor magnitude (Amperes or kA), and current phasor angle (degrees), frequency (Hz) and rate of change of frequency (ROCOF).
Coordinates	Required	Provide phasor data in polar coordinates where magnitudes must be in SI units.
System Frequency	Required	Provide phasor data continuously at frequency between 57 Hz and 62 Hz.
Reporting Rate	Required	Provide <i>synchrophasor</i> data at least once in every one sixtieth of a second (i.e. 60 samples per second).
Time-Tag Format and Accuracy	Required	All <i>synchrophasor</i> data shall be reported in Coordinated Universal Time (UTC time) with zero offset. For each phasor measurement, data shall include a time tag traceable to UTC clock that includes the time and time quality at the time of measurement. The time tag shall accurately

resolve time of measurement to at least 1 $\mu$ s within a specified 100-year period.

Data Format and Accuracy Standard	Required	Data provided to the <i>IESO</i> shall comply with the IEEE Std 60255-118-1-2018.
Network Protocol	Required	Provide <i>synchrophasor</i> data via a site-to-site VPN with the <i>IESO</i> . A public static IP address is required.
Instrumentation Channel	Required	Provide instrument transformers and its corresponding instrumentation channel components with accuracy high enough to be appropriately utilized in <i>IESO</i> real-time applications <sup>(8)</sup> .
Latency	Required	Provide total latency for <i>synchrophasor</i> data from <i>PMU</i> to the <i>IESO</i> control center or <i>IESO</i> owned PDC no more than 500 ms. The <i>market participant</i> shall be required to provide latency of no more than a 100 ms if informed by the <i>IESO</i> that its <i>synchrophasor</i> data is to be used in a Linear State Estimator as part of a Transient Stability program.
Latency	Preferred	Provide total latency for <i>synchrophasor</i> data from <i>PMU</i> to the <i>IESO</i> control center or <i>IESO</i> owned PDC no more than 100 ms.
Bandwidth	Required	Provide communication channels with bandwidth adequate to reliably transmit the volume of <i>PMU</i> data at selected reporting rate. For most <i>electricity storage facilities</i> a bandwidth of 1 Mbps per transmitting <i>PMU</i> device will be sufficient.

<sup>8</sup> This requirement intends to provide flexibility to *market participants* to utilize their current Instrumentation Channel infrastructure with minimum accuracy equal or better than those used for *SCADA* measurements.

Bandwidth	Preferred	Provide dedicated communication channels.
Critical Infrastructure Protection (CIP)	Preferred	<i>Market participants</i> to include <i>synchrophasor</i> data under their <i>NERC</i> Critical Infrastructure Protection (CIP) program.
Redundancy	Required	Provide primary communication path for <i>synchrophasor</i> data to the <i>IESO</i> . The <i>market participant</i> shall be required to provide primary and secondary communication paths for <i>synchrophasor</i> data if informed by the <i>IESO</i> that its data is to be used in a Linear State Estimator as part of a Transient Stability program.
Redundancy	Preferred	Provide primary and secondary communication paths for <i>synchrophasor</i> data to the <i>IESO</i> .
CVT/PT Selection	Preferred	Provide Metering Class Bus CVT or PT measurements where possible or Metering Class Transmission line or feeder CVT/PT measurements for better accuracy.
CT Selection	Preferred	Provide Protection Class CTs measurements where possible to capture the dynamic and fault conditions.

## 4.3 Applicable Electricity Storage Units Connection

(MR Ch. 4 s.7.2)

Figure 4-1 illustrates measurement points for applicable *electricity storage units*.

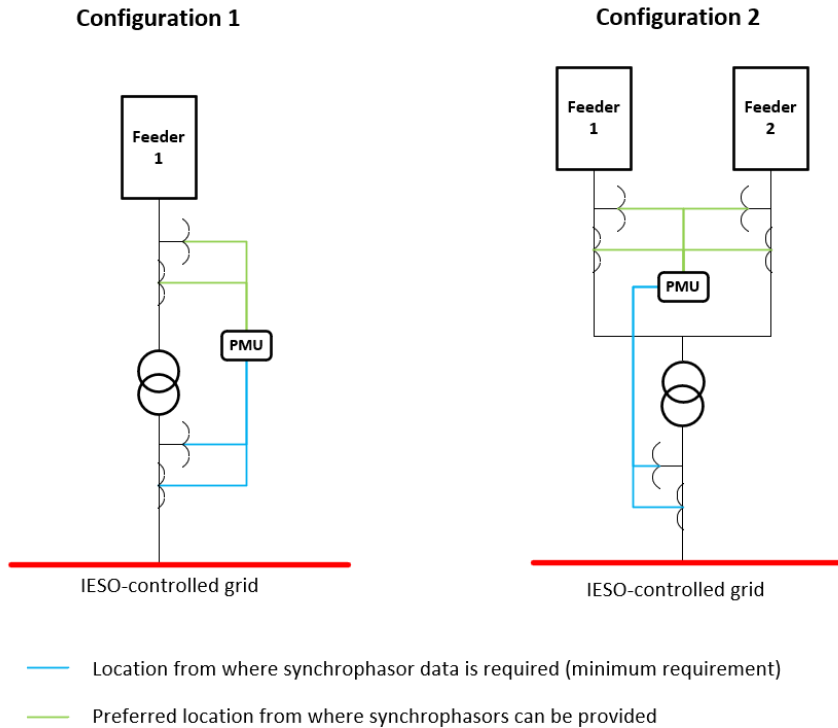

**Figure 4-1: Examples of synchrophasor data measurement locations for different electricity storage facilities and PMU connection configurations**

## 4.4 Reliability, Maintenance and Repair

(MR Ch.4 s.7.7)

MR Ch.4 s.7.7, is applicable to installed *synchrophasor* data devices and associated required infrastructure including instrument transformers, communication channels and PDCs.

– End of Section –

## 5 PMU Registration Process

(MR Ch.4 s.7.2)

This section describes the process of registering *PMUs* with the *IESO*. A *PMU* registration form must be completed for each *PMU* required to transmit data to the *IESO*. See **Figure 5-2**.

In cases where data from *PMUs* will be sent via PDC, the registration information of that PDC is to be provided shown in **Figure 5-3**.

The *IESO* will review the information provided and provide a response about any registration data that might need further clarification. The *PMU* registration information is required for *IESO* to deem that the *PMU* is ready to be connected, and the expected data will be transmitted. Upon completion of the review the *market participant's PMU/PDC* equipment will be entered into a queue for establishing a connection to the *IESO*. *Market participants* will be provided a timeframe for when it will be their turn to connect.

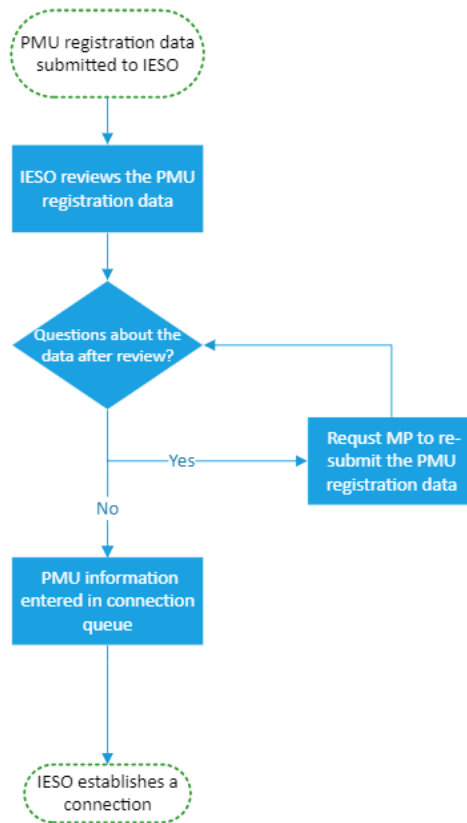

**Figure 5-1: PMU Registration Process**

5. PMU Registration Process

Phasor Measurement Unit (PMU)			
Copy and fill out one form for each PMU.			
Fill in all applicable gray Value fields, and explain with the Comment field as required.			
	Entry Type	Value	IESO Comment
			TO/GO Comment
Location	Company Name:		Maximum 50 Characters
	Substation/Plant Name:		Maximum 50 Characters
	Contact Information for Phasor Data:		
	o Name		
	o Phone		
Phasor Measurement Unit Information	PMU IDCODE		As per assigned IDs; see 'ID Code assignment' worksheet for the IDs available for your company's PMU/PDCs
	PMU In Service Date		mm/dd/yyyy
	STN		Maximum 16 Characters; As defined in 'Naming Conventions' work sheet in this excel file
	PMU Manufacturer		Maximum 50 Characters
	PMU Model (Name and Version)		Maximum 35 Characters
	PMU Firmware Version		Maximum 15 Characters
	PMU Class		'P' or 'M' (2011 std.) or '0' or '1' (2005 std.)
	PMU Reporting Rate		Reporting Rate
	PMU Operational Status		Free form For Example: In Service, On Outage, Not Connected to PDC, In Testing. Maximum 35 Characters
	Time Synchronization Source (for the PMU):		
	o Manufacturer		Maximum 50 Characters
	o Model (Name and/or Version)		Maximum 35 Characters
	Data Sent to - from this PMU (To be repeated for each PDC):		
o PDC (ID Code)		As per assigned IDs; see 'ID Code assignment' worksheet for the IDs available for your company's PMU/PDCs	
o PDC Type		Substation or Regional or Central (Main)	
Voltage Phasor Measurements (To be repeated for each voltage phasor measurement)	CHNAM		Maximum 16 Characters; As defined in 'Naming Conventions' work sheet in this excel file
	If Line Side Measurement:		
	o Line Identifier		Free form field. Could be a description or the ID used by the TO to identify the line when the voltage source is on the line side
	Breaker #1 Identifier		Free form field. Could be a description or the ID used by the TO to identify the Breaker
	Breaker #2 Identifier		Free form field. Could be a description or the ID used by the TO to identify the Breaker
	If Bus Side Measurement:		
	o Bus Identifier		Free form field. Could be a description or the ID used by the TO to identify the Bus if the Voltage source is on the Bus side
	Nominal Voltage		For Example: 115 KV or 230 KV or 500 KV
	Instrument Transformer:		
	o Device Description		
	o Accuracy Class		
o Ratio			
Measurement adjustments required (external to PMU):			
o Scaling Factors		Free Form Field: to identify if there are any scaling adjustments to be done to the measurements. In most cases this should be not applicable	
o Phasor angle adjustment		Free Form Field: to identify if there are any phase angle adjustments to be done to the measurements. In most cases this should be not applicable	
Current Phasor Measurements (To be repeated for each current phasor measurement)	CHNAM		Maximum 16 Characters; As defined in 'Naming Conventions' work sheet in this excel file
	Line Identifier		Free form field. Could be a description or the ID used by the TO to identify the line
	Breaker #1 Identifier		Free form field. Could be a description or the ID used by the TO to identify the Breaker
	Breaker #2 Identifier		Free form field. Could be a description or the ID used by the TO to identify the Breaker
	Nominal Voltage		For Example: 115 KV or 230 KV or 500 KV
	Instrument Transformers (Rows 49 to 51 shall be repeated for each transformer):		
	o Device Description		
	o Accuracy Class		
	o Ratio		
	Measurement adjustments required (external to PMU):		
	o Scaling Factors		Free Form Field: to identify if there are any scaling adjustments to be done to the measurements. In most cases this should be not applicable
o Phasor Angle Adjustment		Free Form Field: to identify if there are any phase angle adjustments to be done to the measurements. In most cases this should be not applicable	

Figure 5-2: Sample PMU Registration Form to be completed. Download PMU

**Registration Form from IESO website**

Phasor Data Concentrator (PDC)				
Copy and fill out one form for each PDC. Fill in all applicable gray Value fields, and explain with the Comment field as required.				
	Entry Type	Value	IESO Comment	TO Comment
<b>Location</b>	Company Name:		Maximum 50 Characters	
	PDC Location (Substation/Plant Name for Substation PDC or Control Center Name for Central PDC):		Maximum 50 Characters	
	Substation/Plant location (if this is a Substation PDC): Latitude –		Maximum 15 Characters	
	Contact Information for PDC administrator:			
	o Name			
	o Phone			
	o Email			
<b>Phasor Data Concentrator (PDC) Information</b>	PDC IDCODE		As per assigned IDs; see 'ID Code assignment' worksheet for the IDs available for your company's PMU/PDCs	
	PDC Vendor		Maximum 50 Characters	
	PDC Firmware Version		Maximum 15 Characters	
	Time Synchronization Source (if used for PDC)			
	o Manufacturer		Maximum 50 Characters	
	o Model (Name and/or Version)		Maximum 35 Characters	
	o Firmware Version		Maximum 15 Characters	
	Data Sent to (To be repeated for each PDC):			
	o PDC (ID Code)		As per assigned IDs; see 'ID Code assignment' worksheet for the IDs available for your company's PMU/PDCs	
	o PDC Type		Substation or Regional or Central (Main)	
<b>Archival Information</b>	Archive Description		Free Form text	
	Archival Rate		Free Form text	
	Archival Format		Free Form text	
	Data Retention Period in days		Free Form text	

**Figure 5-3: Sample PDC Registration Form to be completed. Download the PMU Registration Form from IESO website.**

**– End of Section –**

## 6 PMU Connection Process

(MR Ch.4 s.7.2)

This section defines the required steps for establishing a secure and reliable connection between the *market participant* and the *IESO* for the purpose of *synchrophasor* data being transmitted continuously to the *IESO*. The initiation for this process is the completion of the *PMU* registration process as outlined in the previous section.

For instances where a *market participant* has multiple devices capable of generating *synchrophasor data* at a given *facility* the recommended option is for a PDC to be utilized as it minimizes the amount of VPN connections required between the *IESO* and *market participant*. In addition, PDC helps with the transmission of *synchrophasor data* ensuring all of the data is time-aligned from the various devices at site and transmitting it in a more compact way to the *IESO*. The connection architecture will be discussed in the initial meeting that starts the Connection Process to ensure that the chosen architecture is easy to maintain and administer.

**Table 6-1: Steps involved in establishing connection with the IESO for the transmission of *synchrophasor* data**

Step	Description
6.1 Initial Design Discussion	<i>Market participant</i> and the <i>IESO</i> shall review the networking technical requirements via meeting
6.2 Exchange of VPN Form	<i>Market participant</i> shall complete and submit the VPN configuration form provided by the <i>IESO</i>
6.3 Network and/or Application Validation Meeting	<i>IESO</i> will implement VPN tunnel based on 6.2 above, and once ready initiate a meeting to validate the connection at the network and application levels
6.4 Final Confirmation	Following the application validation meeting, <i>market participant</i> commences transmission of the <i>synchrophasor</i> data and the <i>IESO</i> confirms successful receipt of the data and the PMU connection process is complete.

In **Figure 6-1** the most common ways of transmitting *synchrophasor* data to the *IESO* are illustrated. During the initial design discussion the *market participant* and *IESO* will

determine the details in terms of establishing the connection required for the transmission to take place.

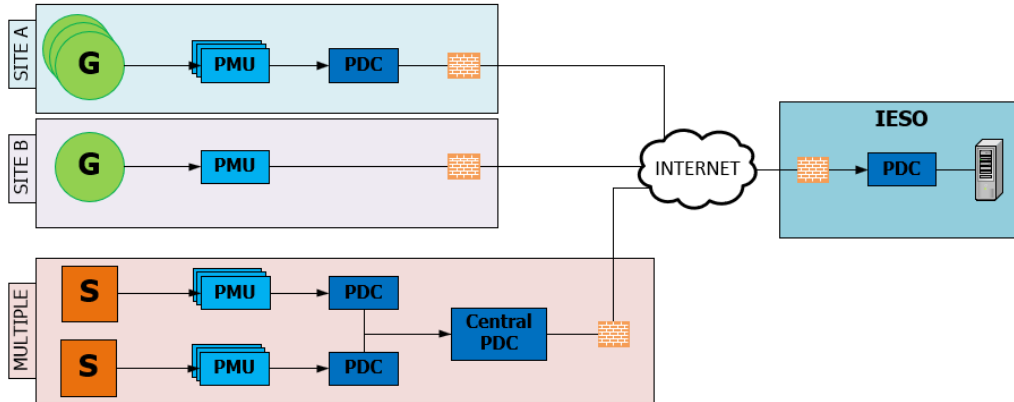

**Figure 6-1: Typical *synchrophasor* data flow architecture based on number of PMUs at a given site and/or number of sites**

**– End of Section –**

**– End of Section –**

**– End of Document –**